

NYPL RESEARCH LIBRARIES

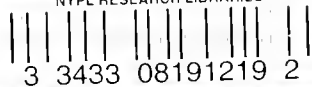

3 3433 08191219 2

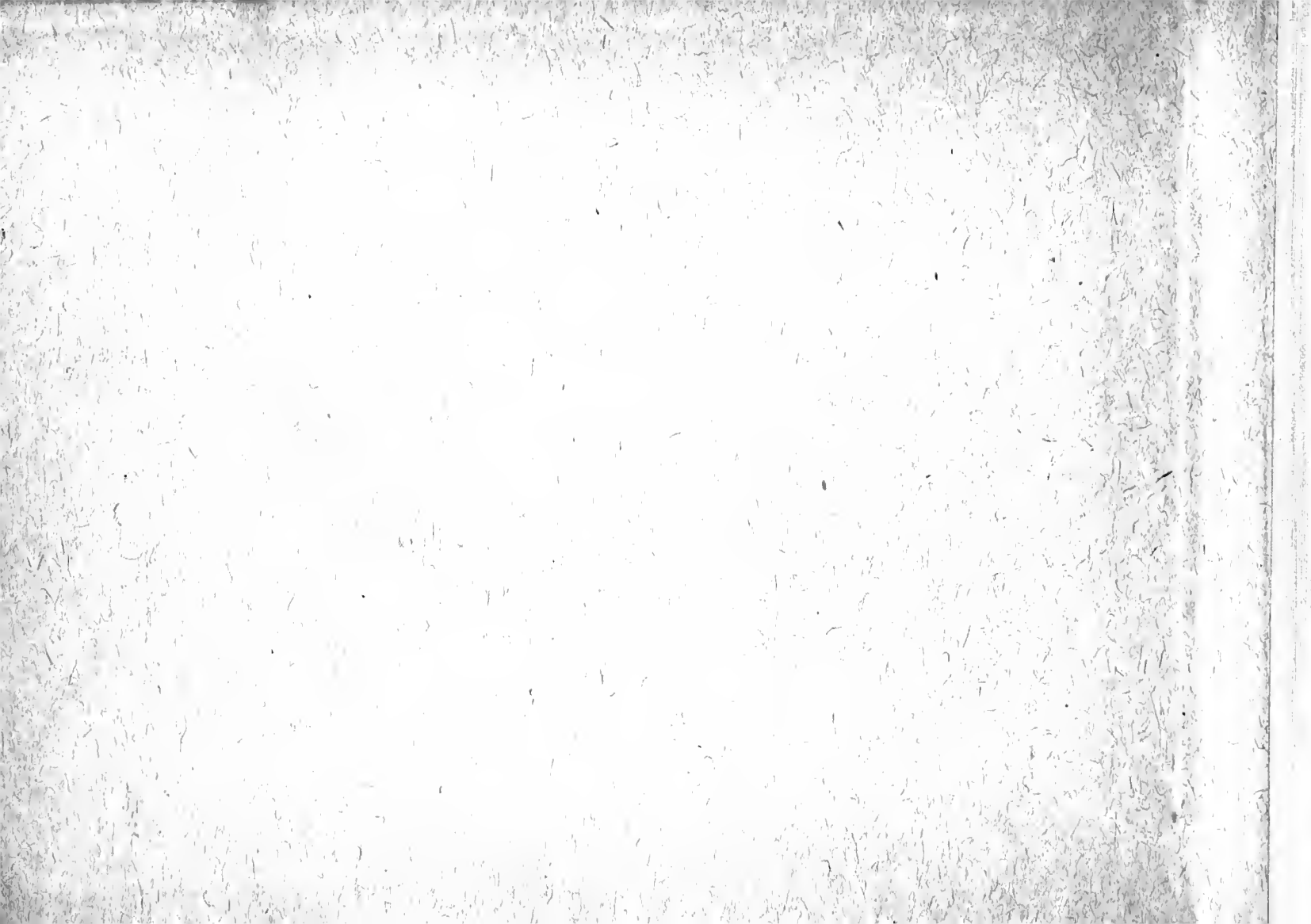

Miller
3-MBF



Digitized by the Internet Archive
in 2008 with funding from
Microsoft Corporation

<http://www.archive.org/details/essentialsofpers00mill>

THE ESSENTIALS OF PERSPECTIVE

WITH ILLUSTRATIONS DRAWN BY THE AUTHOR

BY

L. W. MILLER

Principal of the School of Industrial Art of the Pennsylvania Museum, Philadelphia

155

DISCARDED

NEW YORK

CHARLES SCRIBNER'S SONS

1887

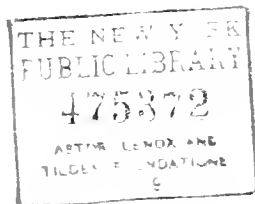

Copyright, 1887, by Charles Scribner's Sons

742

M 614

PREFACE.

I CALL this little book "The Essentials of Perspective," because it seems to me that it contains as much information about the science of which it treats as the artist or the draughtsman ever has occasion to make use of, except under the most unusual conditions.

I do not claim to have discovered any new thing, either in the principles or possible applications of perspective science. But it has occurred to me, as I know it has occurred to many others with a similar experience in teaching drawing, that a book on perspective, which should be exhaustive enough to redeem the study from the contempt with which it is too often treated by artists—an estimate which is, to a considerable extent, justified by such presentations of it as are usually found in the "hand-" and "text-books" in common use—and yet free, as far as possible, from the technical difficulties which the unscientific mind is pretty sure to encounter in the profounder treatises, might be of use.

If, on glancing through the book, some things are found to have been left out which are usually introduced into a work of this kind, I ask the reader to look twice before he finds fault with the omission, as this weeding out of what have seemed, to me, unessential things has been the means on which I have mainly relied in the effort to make clear the really important truths. I have aimed, too, to make the illustrations such as should seem to connect the study with the work of the artist rather than to use them as diagrams by which to demonstrate abstractions, and such also as might, for the most part, be understood without the help of letters of reference.

It may be of interest to teachers of drawing to know that these illustrations are of precisely the same character as those which I have used for many years in teaching perspective from the black-board; and while

x 4058

pupils do not always make as good transcripts of them in their note-books as one would like to see, they make them quite good enough to fix in the mind the lesson which each is intended to convey, and find them infinitely more interesting and practical than the pure theory to which they are so often treated in connection with this branch of study.

The reader who cares to go farther in the scientific study of perspective than I have attempted to lead him will find "Modern Perspective," by Professor W. R. Ware, of Columbia College, the best book for his purpose.

Mr. Ware was my teacher, and I have to thank him for the most that I know about the subject; and I am sure his work remains the most masterly and thorough presentation of it which has yet been made.

L. W. M.

PHILADELPHIA, March, 1887.

CONTENTS.

	PAGE
CHAPTER I. FIRST PRINCIPLES.....	1
CHAPTER II. THE HORIZON	11
CHAPTER III. MEASUREMENT BY MEANS OF PARALLELS	21
CHAPTER IV. MEASUREMENT BY MEANS OF DIAGONALS.....	33
CHAPTER V. MEASUREMENT BY MEANS OF TRIANGLES.....	43
CHAPTER VI. THE PERSPECTIVE OF CURVES	59
CHAPTER VII. A QUESTION OF METHODS.....	63
CHAPTER VIII. SHADOWS	74
CHAPTER IX. REFLECTIONS	83
CHAPTER X. CYLINDRICAL CURVILINEAR OR PANORAMIC PERSPECTIVE	90



THE ESSENTIALS OF PERSPECTIVE.

CHAPTER I.

FIRST PRINCIPLES.

EVERYBODY knows well enough that when you look along a straight street or railway, or on a garden or field planted in regular rows, the lines which you see before you, and which you know to be parallel, seem to slope, or incline toward each other as if they would meet in a point if they were long enough. In other words, all parallel lines *seem* to converge as they recede from the observer. And everybody also knows, or ought to know, and must know before this inquiry can be carried any farther, that any set of parallel lines which may be in sight from the observer's position seem to converge toward a point which is exactly in front of his eye when he looks in the direction which he knows to be that of the actual lines. In the little sketch (Fig. 1) it will be noticed that the lines of most importance all run in one direction, as if they would meet and disappear in one point, and drawings of this kind are sometimes said to be in one-point perspec-

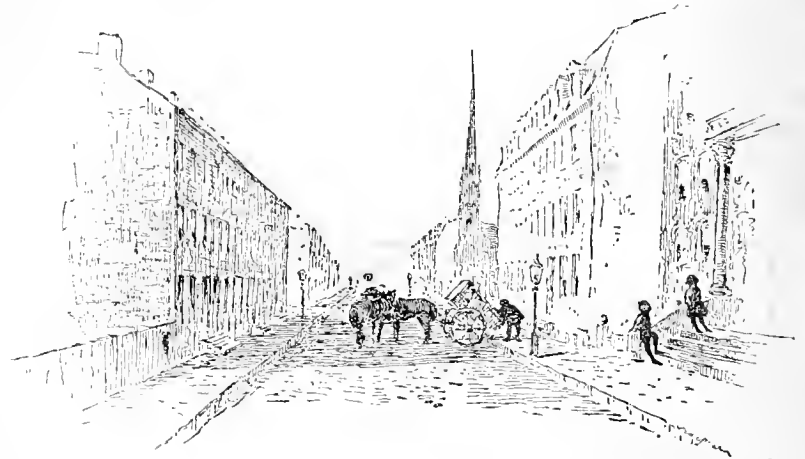

Fig. 1.

tive. Sometimes it is called Parallel Perspective, perhaps because the lines of most importance are all parallel, perhaps because one end or side of each object represented (in this case the end of each house) is parallel with the flat sheet of glass, or paper, or what not, on which the picture is supposed to be drawn. Please note the sketch a moment and try to realize the exact conditions under which it is supposed to have been made. Anyone who lives in a city can reproduce these conditions any day. Get possession of one of the forward seats in a horse car with the window closed and you have everything you want. The window in the end of the car is to be regarded as the surface through which you get the view and on which you might make a picture of it.

This picture (Fig. 1) looks just as if it had been drawn on such a vertical plane (or pane) of glass as the window of the car, which pane of glass would have been parallel with the nearest end of every house which appears in the picture, would it not? Notice, too, that with a few unimportant exceptions such as the line of shadow across the street, the edges of the lantern on the street lamp, and the lines of the gables of the dormer windows—of the church too, if you can make them out—notice that with these few exceptions every outline in the picture is either exactly parallel with that edge of the object for which it stands or it is drawn toward a point which is directly in front of the observer's eye when he looks straight along the street. You will notice, too, that this point is a little to the left of the middle of the street and somewhat higher than the heads of the horses on the coal-cart, from which I hope you will be able to infer that the observer, in order to have obtained such a view as this, must have been standing a little to the left of the middle of the street, and on something high enough to enable him to look over the heads of the horses; and if you understand this you will also understand that the whole character of the picture would be changed if the observer were to move his head, showing that the apparent direction of the sloping lines does not depend at all upon the position of the buildings to which they belong, but simply upon the position of the observer's eye. If this is moved, the point toward which the lines incline (and which we may as well begin to call the vanishing-point, for that is its name) seems to move too; if he were to approach either curbstone, this point would

approach the same curbstone; if he were to raise or depress his head, the vanishing-point would be correspondingly raised or depressed. This may be demonstrated in a very striking way by noting the changes which take place in the view one gets from the window of a moving railway car. The lines of the fences, or roads, or rows of planted corn which run straight away from the track along which you are moving seem to turn on a pivot as you pass them, and to point continually toward a point on the horizon, which seems to move along with you.

Now, what is true in this simple street view is true of any other. I have dwelt a little on this one because it is very simple, and the lessons it has to teach are easily learned. But simple or not, it contains about everything that is necessary to illustrate every principle of the science by. We shall see how variously these principles are applied more readily by means of other illustrations; but the principles themselves could really all be demonstrated by means of this one, and nearly all the most important pictorial work that is ever done is in this same simple elementary "parallel" perspective.

You can, for that matter, draw anything according to the principles of parallel perspective; things seen cornerwise, as this sheepfold (Fig. 2) is, or presenting any number of oblique lines, like the corner of the cottage roof (Fig. 3), just as well as those seen endwise, as is the case with the street in Fig. 1. But the way to do this is something which I will try to show a little further on, and it may be well for the

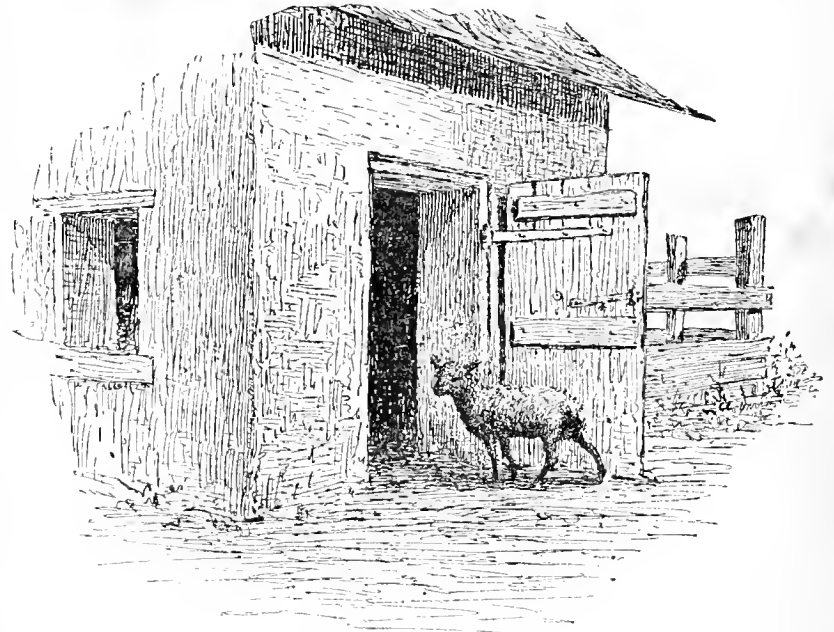

Fig. 2.

present to say that the term is usually applied only to such views of objects as Figs. 1 and 4 illustrate, and that objects which, like the sheepfold, present angles but involve the use of horizontal lines only, are said to be in "angular" or "two-point" perspective; while views which, like Fig. 3, consist mostly of oblique lines, and so would involve, if all the lines were drawn to their vanishing-points, the use of at least three of these, are said to be in "oblique," or three-point perspective. These terms really mean next to nothing, as there may be oblique lines in the simplest views, such as those of the dormer windows in Fig. 1, whose vanishing-points are always to be found if anyone wants them, and as even in such cases as that shown in Fig. 3, there are always ways enough of doing without these points in practice. But the terms are in common enough use, so that I was afraid the reader might think I had omitted to mention some very important matter if I left them out—a consideration, by the way, which has induced me to insert a good many other things which, as far as understanding the principles of perspective is



Fig. 3.

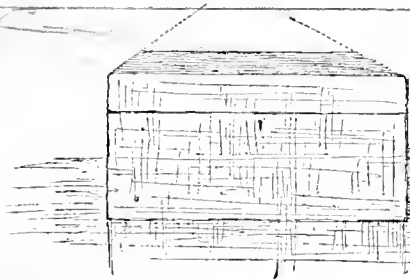

Fig. 4.

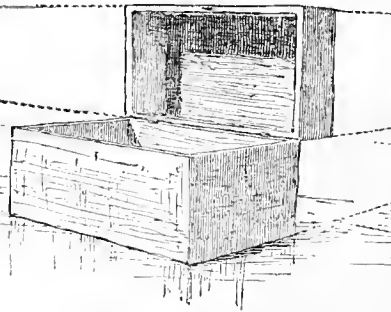

Fig. 5.

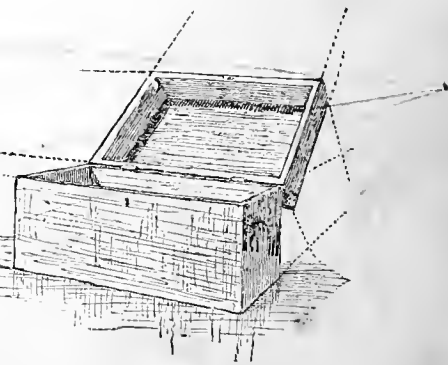

Fig. 6.

concerned, might as well have been ignored altogether. Figs. 4, 5, and 6 illustrate all three of these phases of the subject as applied to one simple object. You see there are three vanishing-points to the lid alone in Fig. 6.

What is true, then, of the view obtained through the forward window of the horse-car is true of that which any window commands, namely, that all lines traced on the glass in such a way as to form true pictures of the objects seen through it will be found to be either parallel with the edges of the objects themselves, or converging toward points which are directly in front of the observer's eye when he looks in the direction in which the edges of the objects are known to run.

Anybody can understand this at a glance in cases where the only lines which have a vanishing-point run straight away from the observer, as in Figs. 1 and 4; but it is not quite so obvious when the lines to be studied run in other directions, and the vanishing-points to be located are more numerous. A little experimenting will, however, convince the student that the law just stated is as true in the one case as in the other.

If he will seat himself before a window which commands a view containing a building or two, not too far away, and which is fitted with a screen of wire gauze to keep out the flies, he will have the best possible apparatus for conducting these experiments; for he can not only draw on the gauze, with a bit of chalk or charcoal, lines which cover, and so give the exact apparent directions of, the edges of the objects he is studying. but, by tying bits of thread to the points on the screen where he locates his vanishing-points, and bringing the other end of each thread to his eye, he will be able to demonstrate, beyond a peradventure, the truth of the rule just stated, that *all the lines in a picture either have just the same direction as the corresponding lines in the object itself, or are drawn toward vanishing-points which are to be found by looking in the direction which the lines of the object are known to*

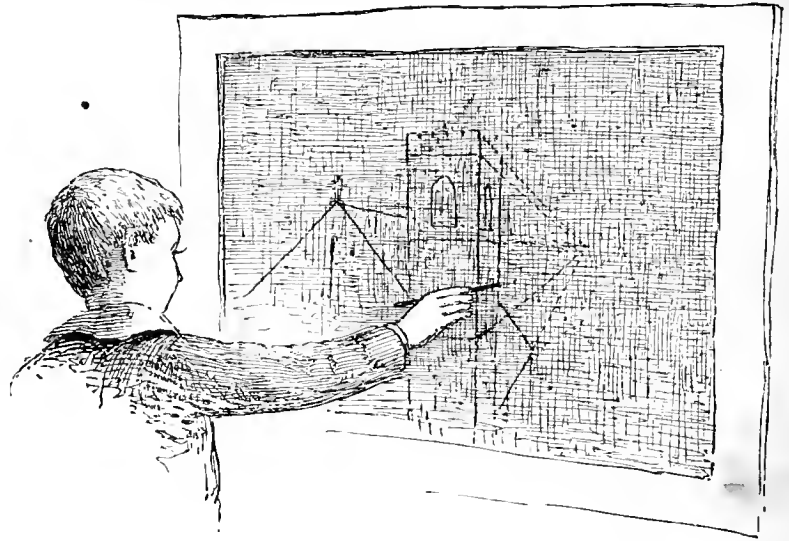

Fig. 7.

follow—for the direction of any one of these threads will be found to be exactly the same as that of the corresponding line or edge of the object represented. Fig. 7 and those which immediately follow it will illustrate the points which I wish you to establish for yourselves at the window screen.

You will soon find when you begin to draw on the screen, that you can only represent what is seen by one eye, and that you have to keep your head pretty still, in order to accomplish anything even then. It is a great deal better, however, for you to find these things out for yourself; so, if you please, they will not be insisted upon here.

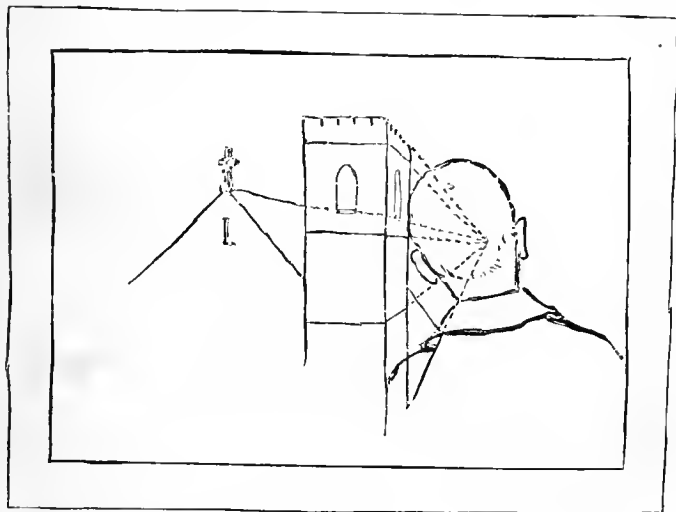

Fig. 8.

A bit of card-board, or very thin metal, with a little hole pricked in it to look through, fixed firmly in an upright position, about two feet in front of the screen, will be of assistance in keeping the “station-point” (for that is what the position of the observer’s eye is called) stationary.

The limits of your picture are as far to the right and left, or up and down, as you can manage to see through this little hole. You may turn your head as much as you have a mind to, and everything you may have seen in books on perspective about the necessity of

keeping the eye fixed, and about perspective not being true except within a certain distance from the centre of your field of vision is all humbug. Such statements have bothered students of perspective more than a little before now. Don’t let them bother you.

The “field of vision” is a term applied to the whole space which your view from the station-point includes. The point directly in front of your eye, when you look squarely at the screen, is manifestly the centre of this field, and is usually called the “centre of vision.” Writers on perspective have sometimes

called the things which have just been defined by different names, but these which I have given are the most common, and are, I think, expressive enough to be easily remembered.

Now, if one were standing directly behind the observer whose position is indicated in Fig. 7, he would see that, with relation to the vanishing-point found in carrying out the lines of the picture of the church, the observer's eye, or "station-point," would be as it is shown in Fig. 8.

The relation of the station-point to the screen, and of the object represented to both of these, is stated diagrammatically in Fig. 9.

Fig. 10 shows how the case would have stood if these relations were altered so as to make the screen stand obliquely as compared with the sides of the church, instead of parallel with the front of it as in Fig. 9.

The dotted lines give in both cases some idea of the size of the drawing on the screen, which in the last instance would be something like Fig. 11.

Remember that all the diagrams are good for is to call your attention to the fact that the line from the station-point to the vanishing-point will, in every case, be *exactly parallel* to the lines of the object with which this point is associated.

If the window at which your experiments are conducted gives you a glimpse of the sea, or

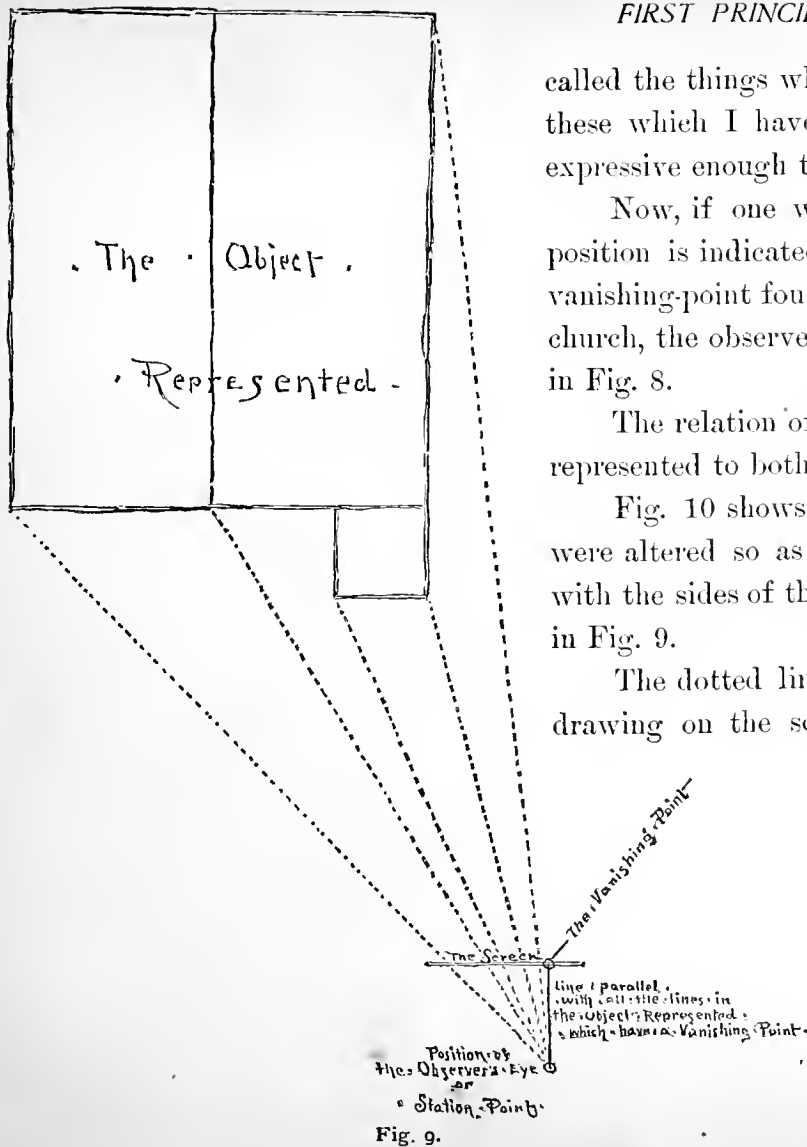

of a flat, open country, where there are no hills or near woods in sight to obstruct the line of the horizon, you will find that all the horizontal or level lines which are anywhere in sight have their vanishing-points somewhere in this horizon.

Do not confine your observations to the level lines however; it is especially desirable that you should pay a good deal of attention to the oblique lines which are to be found in roofs, lattices, the braces of open timber-work, etc., and it will, perhaps, be just as well, after all, if your window does not command a view of the horizon; for you might think too much about it if you had it, and so might fail to observe other things which are of quite as much importance.

Only it would be well to verify for yourself at some window which did command an unobstructed view of the sea or plain, the statement just made, that the vanishing-points of all level lines are to be found in the horizon.

After that you can, in studying any view whatever, locate the horizon with perfect confidence by simply carrying out until they meet any two lines drawn upon your screen to represent parallel horizontal lines. Their vanishing-point will, of course, indicate the place where the horizon is.

You can draw fairly well on the window-pane with a brush of color, and fix the threads to the glass with wafers; but the wire screen will be found to be much the most convenient if any considerable number of lines are to be drawn and tested.

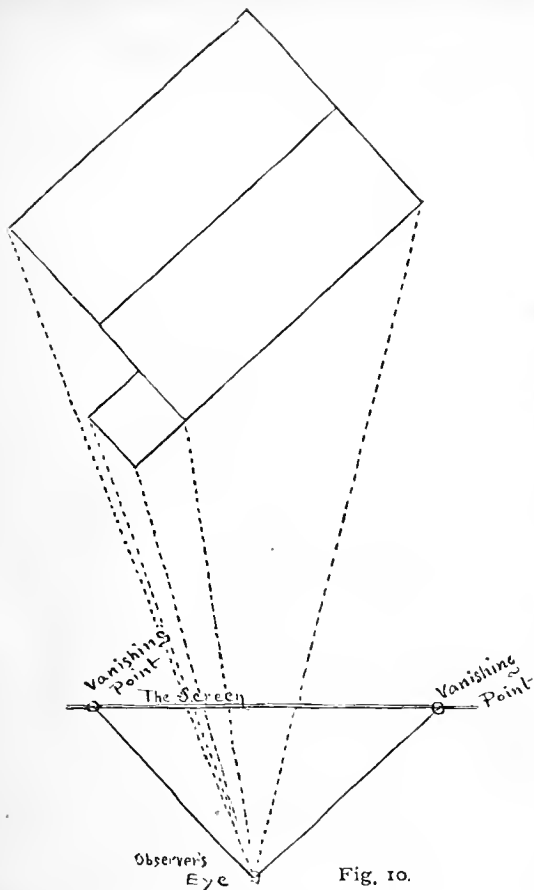

Fig. 10.

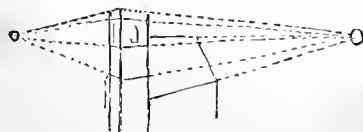

Fig. 11.

If you will convince yourself by a little of this kind of experimenting of the truth of the following statements, nothing that this book contains ought to give you much trouble afterward.

Perspective science is simply the application to the optical laws which these experiments will determine, of a little very elementary geometry; certainly not more than any school-boy ought to know by the time he is fifteen years old.*

Establish, then, to your own satisfaction, these truths by actual observation:

First. All lines or edges in nature which are parallel with your picture-plane are accurately represented by lines having the same directions as themselves, and as any number of such lines or edges that happen to be parallel to each other are still parallel in the picture-plane, they have no vanishing-point at all. Thus the picture of a vertical line will always be vertical, and the slope of any gable, which squarely faces your picture-plane, *or your picture-plane indefinitely extended*, will be just the same in the picture as it is in reality.

Second. When there are two or more such lines or edges as these which are equal in length, the pictures of them will be equal to each other too, and any regular figure which they may form in reality will appear just as regular in the picture. The cart-wheel in Fig. 1, for example, is, or ought to be, perfectly round, and the front of the box in Fig. 4, is a perfect rectangle.

Third. All lines or edges in nature which are not parallel to your picture-plane are represented by lines which have a different direction from that of the lines or edges themselves, and which incline toward a point which may always be found on the picture-plane if this is sufficiently extended.

Fourth. This point is the picture of the place where the line itself would disappear if extended indefinitely.

* It may be well enough to say in this place, that although the picture may be, and occasionally is, supposed to be made on an inclined surface, a series of vertical flat surfaces joined together at an angle, or even on one that is curved, such cases are altogether exceptional and will be considered by themselves by and by, and the main principles of the science are usually to be understood with reference to just such a picture-plane as your upright window screen represents, and just such a station-point as the perforated card-board stands for.

Fifth. This point may be established by means of a line from the station-point to the picture-plane drawn parallel to the lines in the object which vanish at this point.

Sixth. This point being common to all lines running in that direction may also be found by drawing the pictures of any two of them and extending them until they meet.

Seventh. The vanishing-points of all horizontal lines will be found in the horizon.

Eighth. The horizon will be represented by a level line across the picture, which line will be just as high as the observer's eye. Note this carefully, and make sure of the fact that, however high up you may happen to be, you do not have to look *down* to see the horizon.

But this matter of the horizon is one of sufficient importance to be given in a chapter by itself.

CHAPTER II.

THE HORIZON.

OUR observations at the screen have shown us, among other things, that the horizon, whether it is actually in sight or whether its position is determined by finding the vanishing-point of any set of horizontal lines, is always apparently just on a level with the observer's eye, however high or however low that may happen to be; but observe other illustrations of the same phenomenon.

Look at the lines of the bridge in Fig. 12, for example. All the horizontal lines below the eye that are not actually parallel with the horizon seem, you see, to slope upward toward it, while all those above the eye seem just as obviously to slope downward toward it, showing that the only place where the lines do not slope one way or the other must be just at the level of the eye.

Fig. 13 is introduced merely to show that all the lines to be studied may be above the eye. We become so accustomed to thinking of the horizon as the edge of the earth which is beneath our feet, that it is sometimes necessary to be reminded of the fact that it is the vanishing-line of *everything that is level*: whether it is under our feet or over our heads.

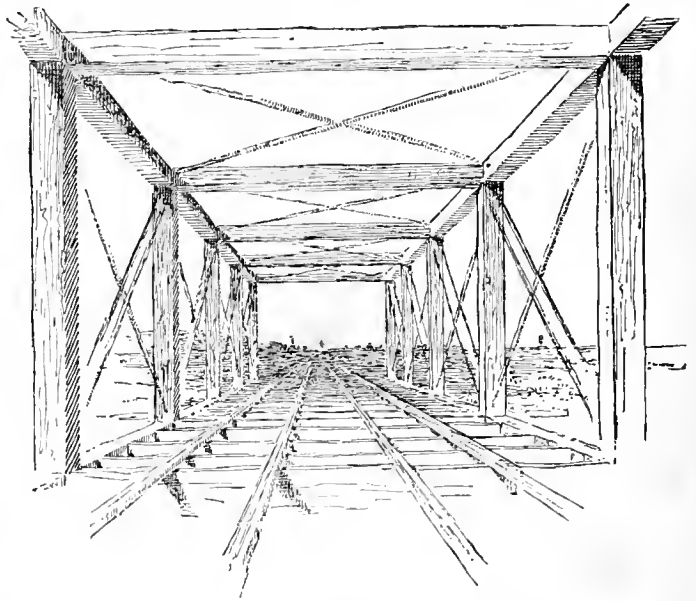

Fig. 12.

The cloud surfaces are often just as level as a plain and present the same perspective effects. Shelley's—

“Glides glimmering o'er

My fleece-like floor

By the midnight breezes strewn”—

show that he had observed this more accurately than a good many landscape painters have

done.

Now, when you think of it, any level line of whose existence it is possible to conceive may be thought of as drawn on a plane surface or floor, may it not? and if you imagine any horizontal line which you have occasion to draw as lying in such a plane, or on such a floor (which means the

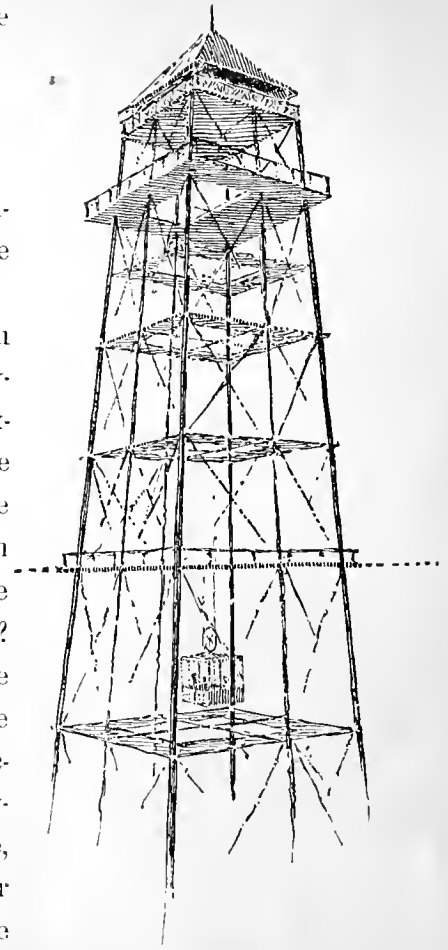

Fig. 14.



Fig. 13.

same thing), you can easily see that the only place where the line and its vanishing-point and the floor itself would all be lost in one straight line would be that in which the floor on which the line was drawn happened to be seen edgewise, as one of them is in this little sketch of the obser-

vatory (Fig. 14). And so you can always locate the horizon accurately if you can manage to get a glimpse anywhere of a flat surface which is seen edgewise. Wherever in your picture or in the view which forms the subject of it, a level surface is seen edgewise, it will appear as a straight line which exactly coincides with the horizon.

Now, if this simple and very obvious fact were always borne in mind it would enable artists to avoid some very awkward mistakes. Fig. 15 shows one of these mistakes. It occurred in a picture shown at one of the regular exhibitions in Philadelphia a little while ago.

I have not copied the picture (the artist would never have forgiven me if I had done that) but I have copied the mistake which it contained; slightly exaggerated it may be, but certainly not much. It was just such a subject as this—and it was not painted by a beginner either, but by a very good artist, else I would not have selected it—long lines in the buildings on both sides of the picture ran, each set toward its proper vanishing-point, but the two vanishing-points were unfortunately not on a level, and so the horizon could not have been level itself, as it must have been if it had coincided with a horizontal plane seen edgewise. Such a plane in this case as you see, would pass through the tops of the windows of the building on the right if we regard the left hand vanishing-point as properly placed.

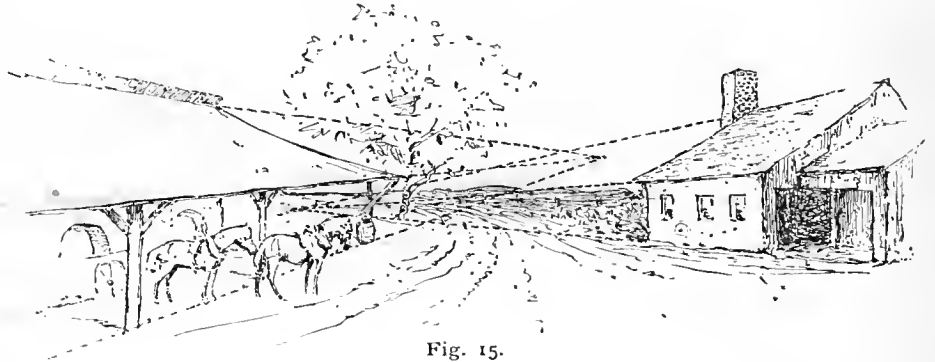

A very scientific and comprehensive way of regarding all the lines which occur in a picture is to think of them with reference to the planes in which they lie. This is sometimes a little difficult where the lines are isolated, but it will be found very useful in cases where the planes are as readily observed as the lines

themselves, as they certainly are in the sketch of the bridge (Fig. 12), or, better still perhaps, in this one of an elevated railroad (Fig. 16).

In both of these all the lines of any importance are either in horizontal or in vertical planes—and what I want you to notice about them is, that the vanishing-points of the lines in the vertical planes bear just the same relation to each other as those in the horizontal planes do; that is, they are always to be found along a line which would coincide with one of these same planes seen edgewise if there should happen to be such a plane in the right place. In Fig. 16, as you see, the vertical planes are purposely given more prominence than the others and one of them is conveniently seen edgewise, and the fact noted above is apparent enough. The line in which the vanishing-points are situated is vertical in this case, of course, because a vertical plane seen edgewise cannot appear like anything except a vertical line. It is equally clear, I hope, that however many different directions the lines of the braces in the supports to this railroad might have had, the vanishing-points of all of them must have been in this vertical line.

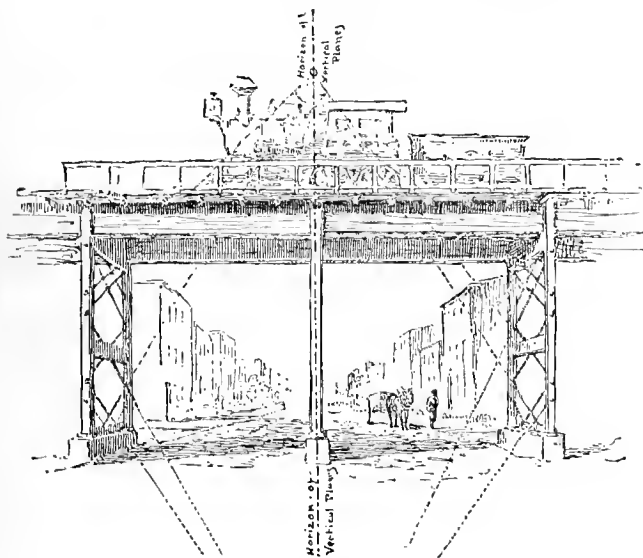

Fig. 16.

Experiment with this drawing, or by means of the screen with any view that will give you the same kind of lines, and see if you can make the vanishing-points come anywhere else except along this line.

Now, to show how easy it is to overlook so obvious a fact as this, I give, in Fig. 17, a cut which is copied exactly from one of the illustrations to a series of articles on perspective which appeared in one of the best of our art magazines only the other day. It is supposed to show how to draw a house with a hip-roof when you want to be very accurate about it.

What the author of this instructive diagram knew about perspective was that pictures of parallel lines have a common vanishing-point, but what he failed to notice was that the gable-end of his house was a vertical wall! If he had seen this he must have known that one vanishing-point would be right over the other.

It has not seemed to be worth while to make many of the illustrations in this book large enough to include all the vanishing-points, but the reader can find any one that he has any doubts about very readily by laying on a ruler.

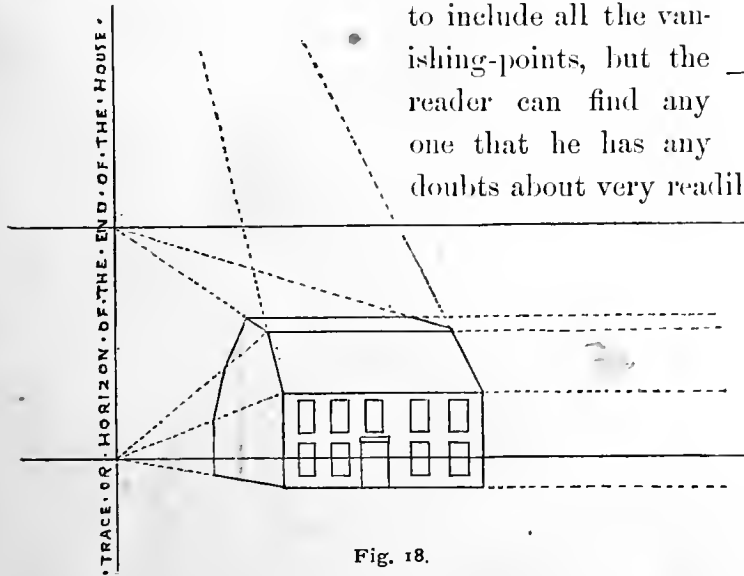

Fig. 18.

as they are perfectly parallel in the diagram. Fig. 19 shows that what has just been observed regarding horizontal and vertical planes is just as true of those which are oblique.

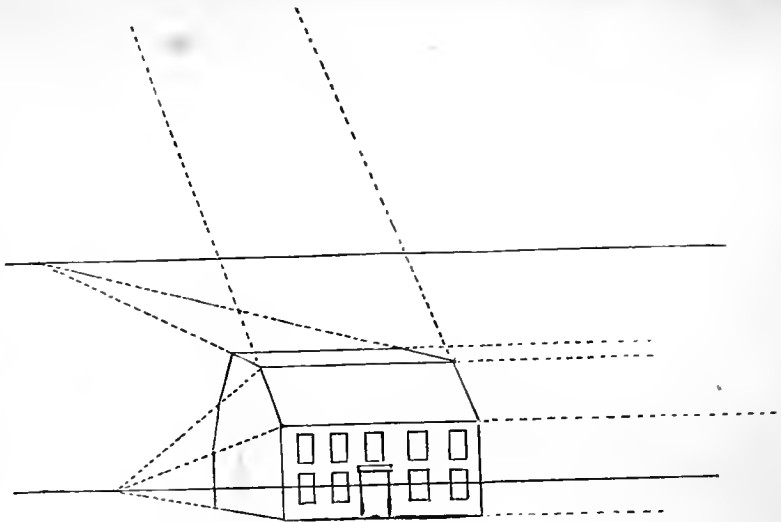

Fig. 17.

If he cares to test the longest inclined lines in Fig. 17, he will find them still farther out of the way than the short ones are. The way in which the drawing should have been made is shown in Fig. 18.

As printed in the magazine the illustration contained another error, for the horizontal lines which run off to the right are described as having started to go "to the vanishing-point," a destination which anybody can see they will never reach,

The roof of the porch is seen edgewise and its edge coincides with the line in which the vanishing-points of all the lines in the other roofs, which are parallel with this one, are situated.

I wish you would take a ruler and test this drawing and see that what has just been stated is true, and that it makes no difference at all whether some of the lines in the roofs are horizontal or not.

No matter what their direction may be, they lie in oblique planes, and that is enough. You will find their vanishing-points in the oblique line of which the edge of the roof of the porch forms a part.

If you care to think of these horizontal lines as lying in horizontal planes too, you are quite at liberty to do so, and you will find their vanishing-points in the level horizon *just where the oblique line crosses it*.

There might be roofs having half a dozen different inclinations in the picture, but as long as their horizontal edges were all parallel, the oblique lines which indicated the actual slope of the different roofs would all cross each other at the same point in the horizon. Fig. 20 illustrates this. The buildings in this sketch (Fig. 20) all stand either parallel with, or at right angles to, each other, so that all the horizontal lines in the picture vanish either at the point in the horizon where the other lines cross it, or at one other which is outside the picture, to the right.

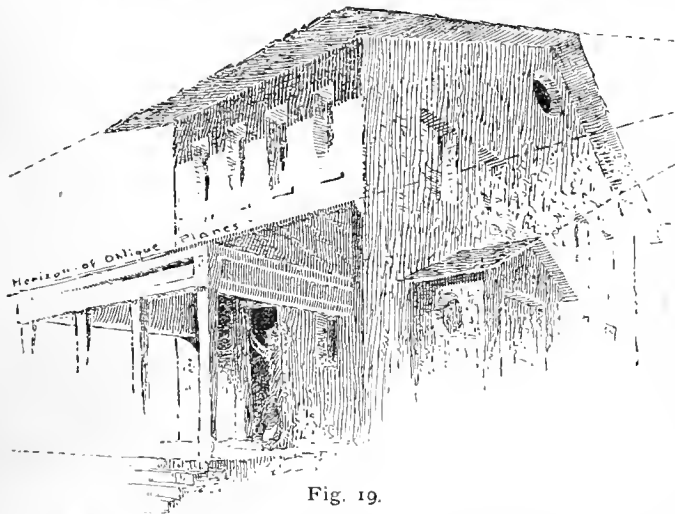

Fig. 19.

All the roofs have the same slant as those of the house in the immediate foreground; that is, they are all just as steep as one or the other of these, but as some of the buildings stand at right angles to this one, of course the lines of some of the roofs have other vanishing-points than those employed in drawing the nearest ones. In studying the sketch, do not mind any of the roofs except those which are parallel to those of the nearest house.

These are the left-hand roof of the tower, which is parallel to the left-hand roof in the foreground, as

it is to the left-hand roofs of the big building close beside the tower, and the right-hand roof of the low, dark building in the middle of the picture, which is parallel with that part of the roof in the foreground which comes nearest to being level.

Now note the fact, please, that most of the horizontal lines in the picture are just as obviously in vertical planes as in either horizontal or oblique ones, and that their vanishing-point is in a vertical line just as much as in either of the others; and that the vanishing-points of the roofs of buildings which face the same way as the big building to the extreme right does, are to be found somewhere up or down this vertical line.

The same state of things exists at the vanishing-point which is not shown in the picture, and you could not have a better exercise than to make a tracing of this drawing, and, having fastened it to a drawing-board, to go over it with a ruler and find all the vanishing-points that were used in making it.

Notice, too, that one side of the chimney to the left, is seen edgewise on the vertical line of most importance, and that the top of another chimney is seen edgewise and so coincides with the horizon.

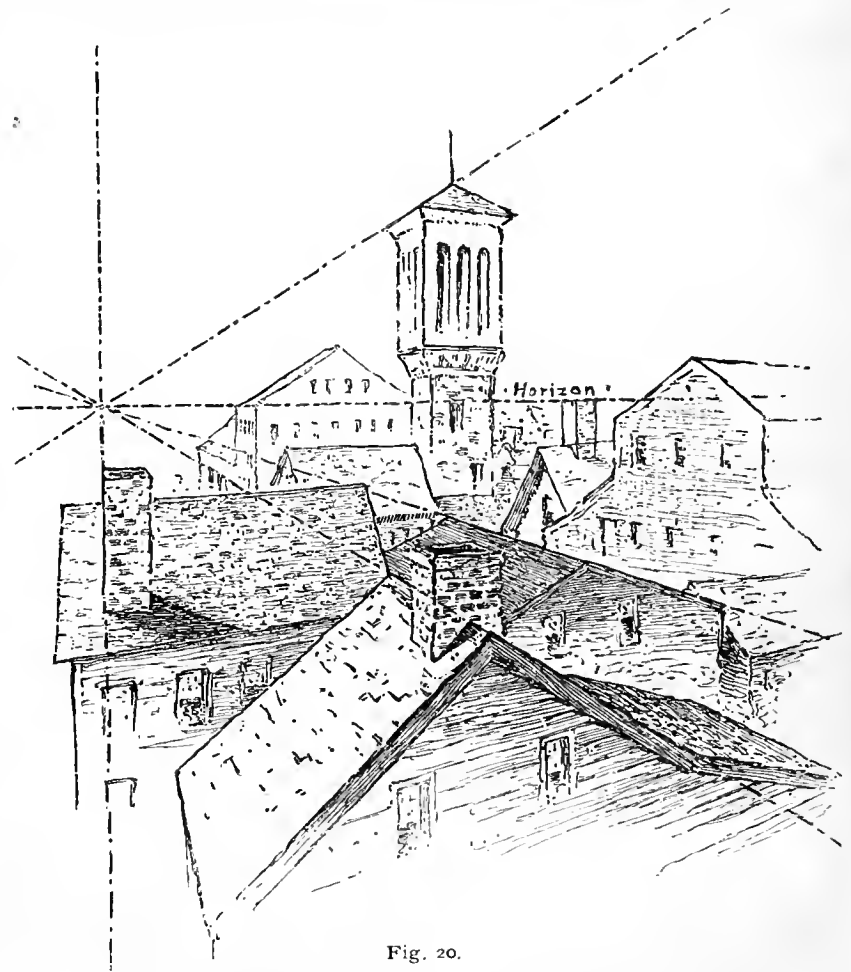

Fig. 20.

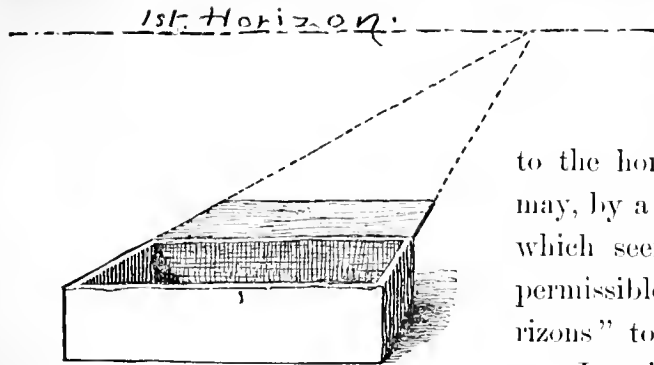

Fig. 21.

whole business very much if we adopt this name for them; and

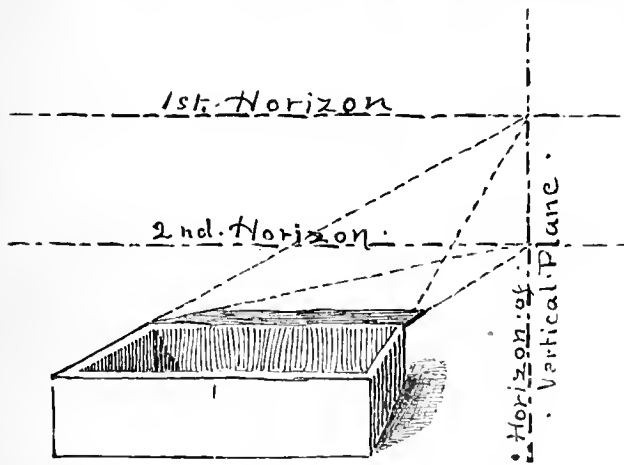

Fig. 22.

in front of the observer. The inclination has no other effect on the perspective calculations involved than

These lines across the picture, indicating the actual directions of the different planes, bear exactly the same relation to the planes which they represent as the horizon bears to the horizontal planes. It has been suggested* that all such lines may, by a figure of speech which seems to be quite permissible, be called "horizons" too.

It will simplify the whole business very much if we adopt this name for them; and so, wherever it has seemed desirable to indicate any of these lines by printing names on them, you will see that they have been called horizons, and they will hereafter be mentioned by that name in the text.

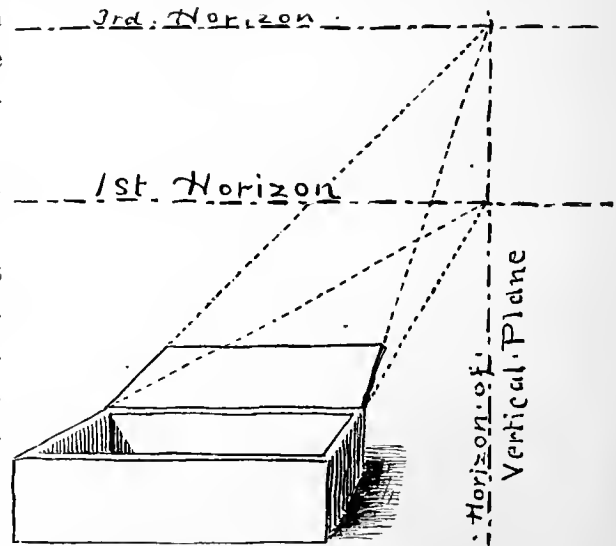

Fig. 23.

A very interesting class of perspective phenomena is that represented by planes which incline either up or down, directly in front of the observer. The inclination has no other effect on the perspective calculations involved than

* By Prof. Ware, author of *Modern Perspective*.

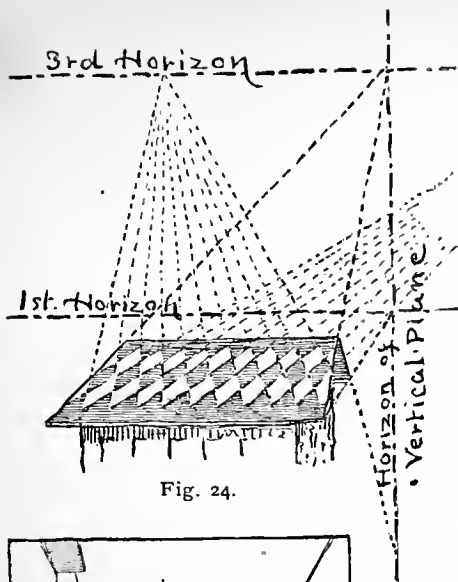

Fig. 24.

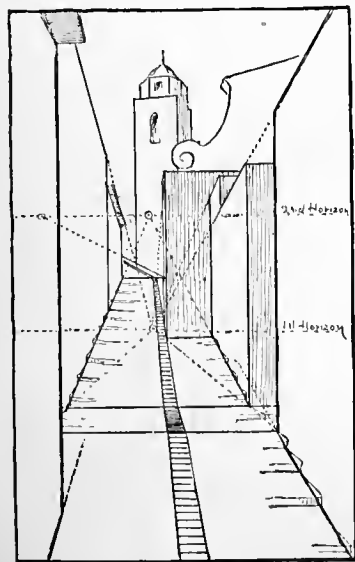

Fig. 25.

to raise or depress the original horizon with the vanishing-points which happen to be situated in it. The sketches of a box given on page 18 (Figs. 21, 22, and 23) show this, the original horizon being indicated as the "first horizon" and the others as second and third in the order in which they are employed. In this particular case it would not be necessary to have these horizontal "horizons" at all—that of the vertical plane in which the end of the lid moves up and down answering every purpose—but it might be convenient to have them sometimes, and so their positions are indicated here.

Suppose, for instance, that instead of the box-lid shown in Fig. 23 we had a roof to draw covered with slates or tiles, then the vanishing-points of the edges of these would be

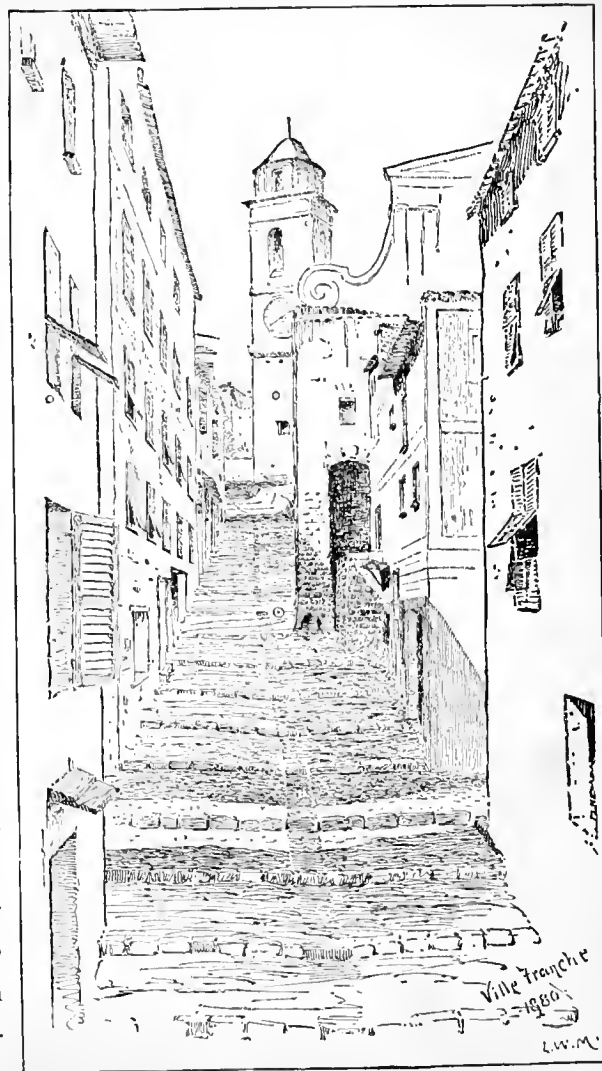

Fig. 26.

somewhere in this "third horizon." The effect is shown in Fig. 24. The upper horizon in this figure is numbered "third" to correspond with Fig. 23 for the sake of the comparison just suggested; but in this view of a street in Ville Franche (Fig. 26, or rather in the little diagram, Fig. 25, which explains the construction of it), the two "horizons" are numbered in the natural order. It would only have confused this diagram to draw the vertical "horizon," but you will see that the two principal vanishing-points would be in such a line if it were to be drawn.

Notice that all the level lines in the picture run to vanishing-points in the original or first horizon, while the lines of the street, being inclined, vanish higher up. Toward the top of the picture the street turns to the left, but you can see by the diagram that the slope remains the same, because its vanishing-point is still in the same "horizon." It only remains to be said that the little street crossing the picture horizontally near the bottom is level, and the slight bend in the gutter in the middle of the street, which shows plainly enough in Fig. 26, has been left out of the diagram for the sake of simplifying it.

CHAPTER III.

ONE CLASS OF MEASUREMENTS.—THOSE OBTAINED BY MEANS OF PARALLELS.

THE principles of perspective have thus far been considered with reference only to the direction of the lines of the picture. It remains to consider them as applied to fixing the sizes of the objects represented. In the first place, let it be clearly understood that the only measurements which are of any consequence to the draughtsman are *relative* measurements. As far as the artist is concerned, he never thinks of any others; but architects and others who work from plans and elevations which are drawn to scale do indeed use the actual measures, because in their case that is the most convenient way, but even then the actual measures become relative as fast as they are applied to the drawing, and these last are the only ones which appear in the result.

For the term “drawing to scale,” an expression constantly used in connection with the construction of geometrical plans and diagrams, has absolutely no significance when applied to a drawing in perspective. You may draw two or three lines in it by scale if you wish, but all the others will have to be measured by means of these; and even the first two or three may be put in just exactly as well without reference to any scale at all, and, indeed, much better, as far as producing a good effect is concerned.

No one can tell in looking at a perspective drawing whether a building is twenty feet high or fifty feet, except by comparing it with some other object for which we carry a fairly accurate standard in our minds. Steps, for example, are of about the same height for all kinds of buildings, and furnish a pretty good standard by which to measure other things; and lamp-posts, gate-ways for foot-paths, etc., serve a similar purpose. The commonest and surest standard of heights is, however, the human figure. The horse answers pretty well, but you are not so sure of him. A pony may easily be mistaken for a horse, but a child will never be mis-

taken for a man if he has been drawn in any respectable fashion; and so the magnitudes of a picture become intelligible the moment the human figure is introduced.

Then, a word regarding the amount of measuring which it is necessary to do will be in order. Students sometimes give themselves a great deal of unnecessary trouble about this.

You can, of course, space off with mathematical precision the width of every moulding, and the size of



Fig. 27.

every ornament, in the cornice of the building you want to draw—you may even determine exactly toward which point of the compass the weathercock is pointing, and the length of the sparrow's tail on the point of the gable; but if you are really trying to draw the building you will not trouble yourself about these things, or rather, if you can draw it at all, you will settle all such details accurately enough without resorting to mechanical methods. Not only is it unnecessary in practice to determine with precision the measurements of insignificant details, but the habit of doing so has often had the effect of diverting the mind from the more important phases of the sci-

ence, and even of discrediting it altogether. It is hard to account for the size of the bugbear which this study has grown to be, among students of art, on any other ground than that of the gradual obscuring of the main questions which it presents by the host of unimportant, although often amusing, ones which suggest themselves to the student. One who has mastered the principles of the science thoroughly often finds the solution of such problems extremely diverting; but they are very perplexing to the beginner, and should not be allowed to embarrass him in his efforts to grasp the central, and only essential, truths.

Two kinds of measurements are employed in making pictures. The first enables us to determine the apparent size of an object with reference to some very obvious dimension—its height, for instance; the other relates to the foreshortening of objects, and to fixing distances between them, along lines which run to a vanishing-point.

The two processes are quite distinct, although they may not seem to be so at first. Look at Fig. 27, for instance. It is quite a different, and a very much easier, matter to determine how high one driver's head ought to be, as compared with the other's, than it would be to measure the distance between the two. Now, the length of the house might be compared with that of another one which was known to stand parallel with it—supposing such a one to have appeared in the picture—by just such a process as that employed to determine the relative heights of the two men; but the width of the end of the house—which, as you see, faces the road—would have to be determined by the same method as that which would be employed to measure the distance between the carts.

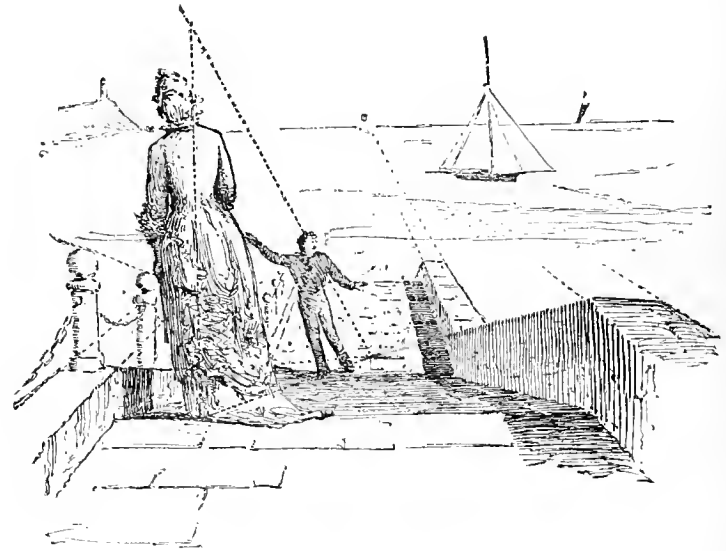

Fig. 28.

The same is manifestly true of the spacing of the posts in the fence, or of the widths of the windows, and, generally, of all distances which one has occasion to measure along lines which are said to run "into the picture," because they go to a vanishing-point.

The same thing is shown in Fig. 28, where it is perhaps a little clearer still, as only straight lines have

been employed in the lines running "into the picture;" and as the widths of the walls and the pathway are indicated by lines parallel with the picture-plane, the measurements are applied to them as well as to the height of the two figures, and in exactly the same way.

The construction in these two illustrations is precisely the same as that in Fig. 25, except that in these the slope is downward instead of upward. In all such cases as those just given, the only mathematical principle involved in making the measurements is the very simple proposition—as nearly self-evident, perhaps, as anything can be—that *parallels between parallels are equal*. In both these examples the lines representing

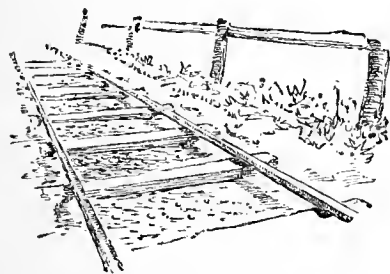

Fig. 29.

the height of the objects are known to be parallel to each other, because they are both vertical, and the line through the top of both is known to be parallel to that through the bottom, because it has the same vanishing-point; and as parallels between parallels must be equal, the height of the object which is farthest off must be accurately indicated by the vertical line which is nearest to us, and that is all there is to be said about it.

The line on the ground is the first one to be drawn, because that will give the vanishing-point whenever it cuts the horizon of the plane in which it lies. This point happens, in Fig. 28, to be the same point as that used in drawing the inclined walk, but that is only because the line through the feet of the two figures is parallel to those of the walls at the sides. In the same way, the lines running downhill from one cart to the other, in Fig. 27, are parallel to those of the fence. These two figures illustrate the principle only as applied to the measurement of lines which are parallel to the picture-plane; but as far as measuring one line by another which is parallel to it is concerned, the rule applies to any others just as well. You are just as sure, for example, that the railroad-ties in Fig. 29—that part of them, at least, which lies between the rails—are all of the same length, as you are that the fence-posts are all of the same height.

Observe that this does not contradict what was said on the preceding page about the impossibility

of measuring distances by this method along lines which run to a vanishing-point. Strictly speaking, we do not measure the ties in Fig. 29 at all—we only know that whatever the length of one of them is, that of

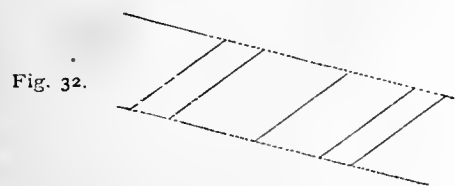
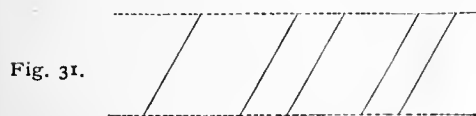

all the others is the same. Figs. 30, 31, and 32 illustrate in a general and abstract way the truth of the proposition just stated. As long as the dotted lines in either figure are parallel, the lines between them, being also parallel to each other, must be equal to each other in length, whatever the direction of any of the lines may be.

Fig. 33 is Fig. 30 seen in perspective, except that the short lines in it are evenly spaced, to correspond with the railroad-ties shown in Fig. 29, while in Fig. 30 these spaces are irregular.

All this seems very obvious and simple, no doubt, but it is often overlooked by artists, and most of the mistakes which are usually made are violations of just such simple rules as this. The measurements in Fig. 34

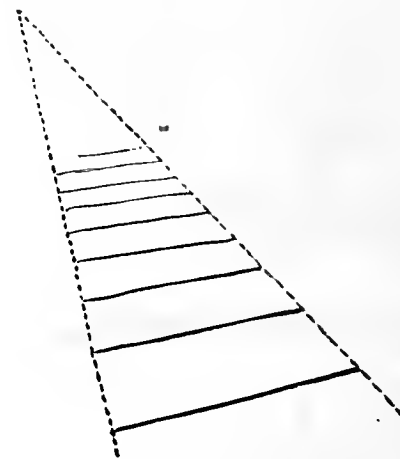

Fig. 33.

are copied carefully from a drawing made by the artist himself of a picture exhibited at the Pennsylvania Academy a few seasons ago. The actual forms of the picture are not copied, for obvious reasons, but every measurement indicated here is taken very carefully from the original work.

I wish the student would study this little picture long enough to satisfy himself regarding the importance of the principle which it is designed to illustrate. The error it contains is a very common one, and discussions about it sometimes become extremely perplexing. But I want the reader to satisfy himself by a little reflection that it is really a very easy

matter to correct it, and that there can be no possible excuse for him if it ever occurs in his own work. Please notice that, as the whole foreground is obviously intended to be level, a line from the feet of the figure through any one of those belonging to the cows must be a horizontal line; and being horizontal, it would have its vanishing-point in the horizon—which, happily for us, is in plain sight. It is only necessary, then, to draw

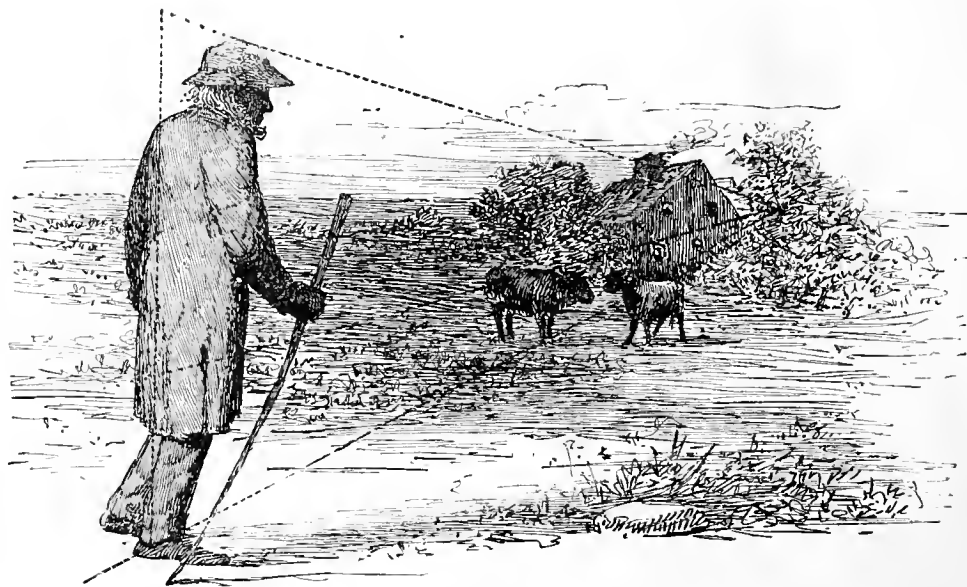

Fig. 34.

such a line, and to continue it until it cuts the horizon to find the vanishing-point, and then to remember that any line that vanishes at the same point must be parallel to this one.

If such a parallel is drawn at that part of the cow's back, in Fig. 34, which is directly over the feet through which the first line passed, it will, as you see, cut the old man's leg about half-way up the thigh, showing that if the cow were standing beside him her back would come no higher than this.

The size of the house is best indicated by the line through the top of the old man's head. Imagine him walking along the line on the ground until he reaches the house, and you will convince yourself that he is almost as tall as the house itself. Fig. 35 shows how the mistake might have been corrected without changing the size of the figure.

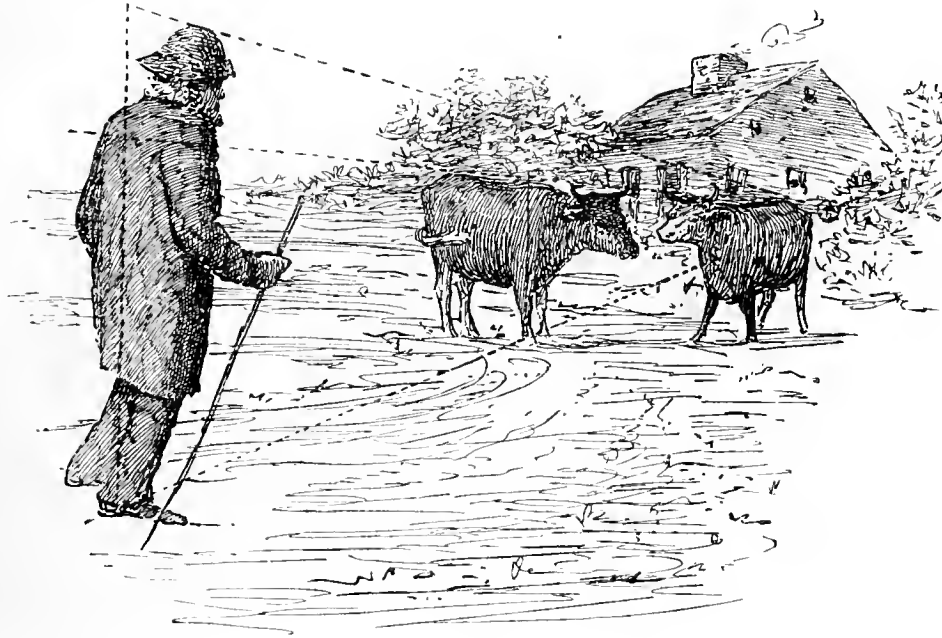

Fig. 35.

Fig. 36, a tracing from a photograph of Raphael's cartoon "Paul preaching at Athens," is introduced to show how the same test may be applied to drawings in which the objects to be measured—one by means of another—are not on the same level. The principal figure in this composition is standing on a raised platform, three steps higher than the level of the pavement on which his audience is grouped. As he is standing close

to the edge of the top step, however, it is a very easy matter to find out just how much these three steps amount to, and so to locate the level of the pavement at a point directly under the preacher's feet. Then a line from this point through the feet of any one of the figures standing in the street must be level, and its

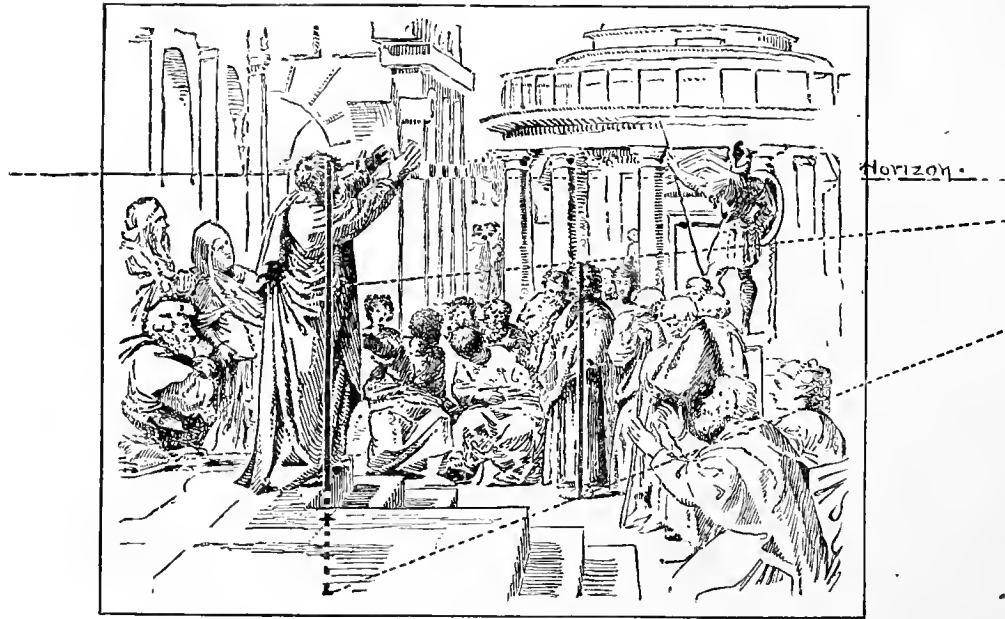

Fig. 36.

vanishing-point would be found as in Fig. 34. The horizon is not in sight, it is true, but it can easily be located by carrying out any two horizontal lines in the picture until they meet. Then a line through the second man's head, parallel to that through his feet, enables us to compare his height with that of the principal figure.

Fig. 37 gives this business of the measurement by itself. Raphael's drawing is very accurate, as you see, the preacher being very properly represented as about half a head taller than the little man on the pavement, who has been selected to compare him with. It is not always, however, that even the work of the

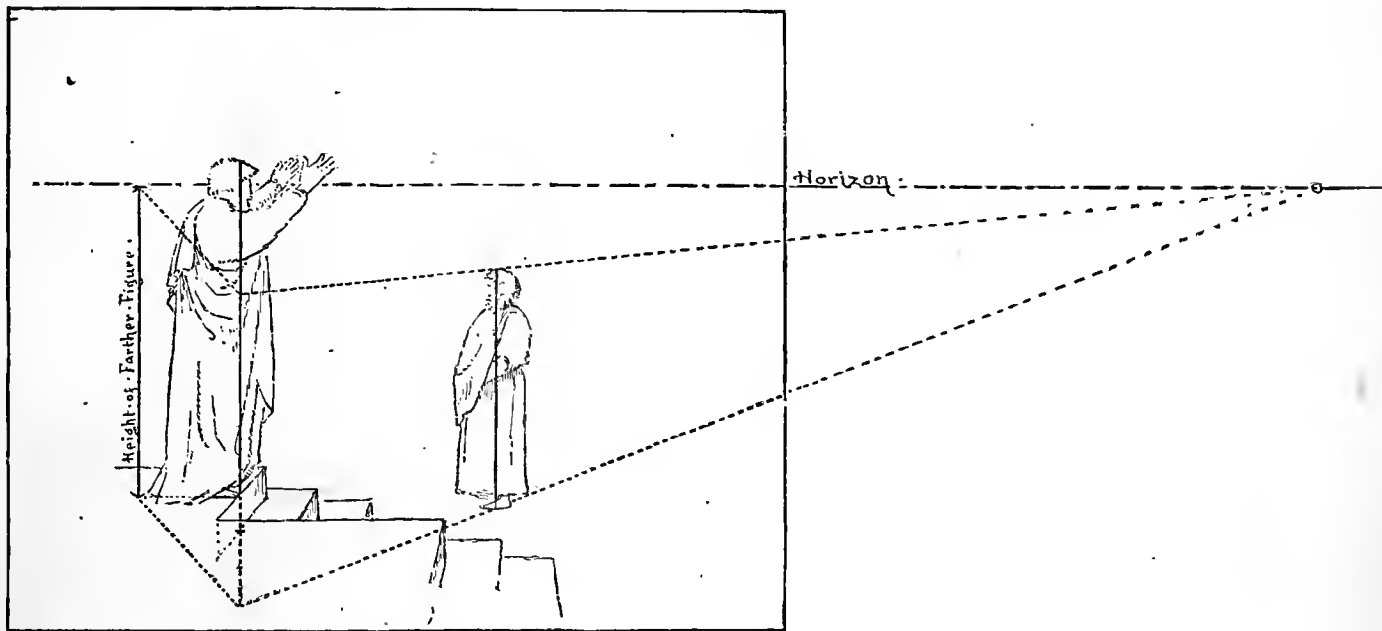

Fig. 37.

masters will bear such a test as this. Fig. 38 is traced from a photograph of Tintoretto's "Presentation of the Virgin." It has been treated in precisely the same way as the last picture; and if the comparison of one figure with another is not quite so direct as in the other case, it is only because all the figures are on steps, which are, moreover, curved instead of straight.

That the nearer figure is lower than the farther one, instead of higher, will, I hope, not give the reader any trouble. It is to be noted that she is bending over a little; and allowance has been made for this in the



Fig. 38.

diagram (Fig. 39), in which lines showing the height of the two figures are placed side by side. The painter may have had a very good reason for making the woman who is half-way up the steps rather more than a head taller than the one at the bottom; whether he had or not does not form the subject of the present

inquiry, which is only concerned with establishing the fact that she is unquestionably considerably the taller of the two—and on the face of it, taken in connection with other peculiarities of the picture, it does

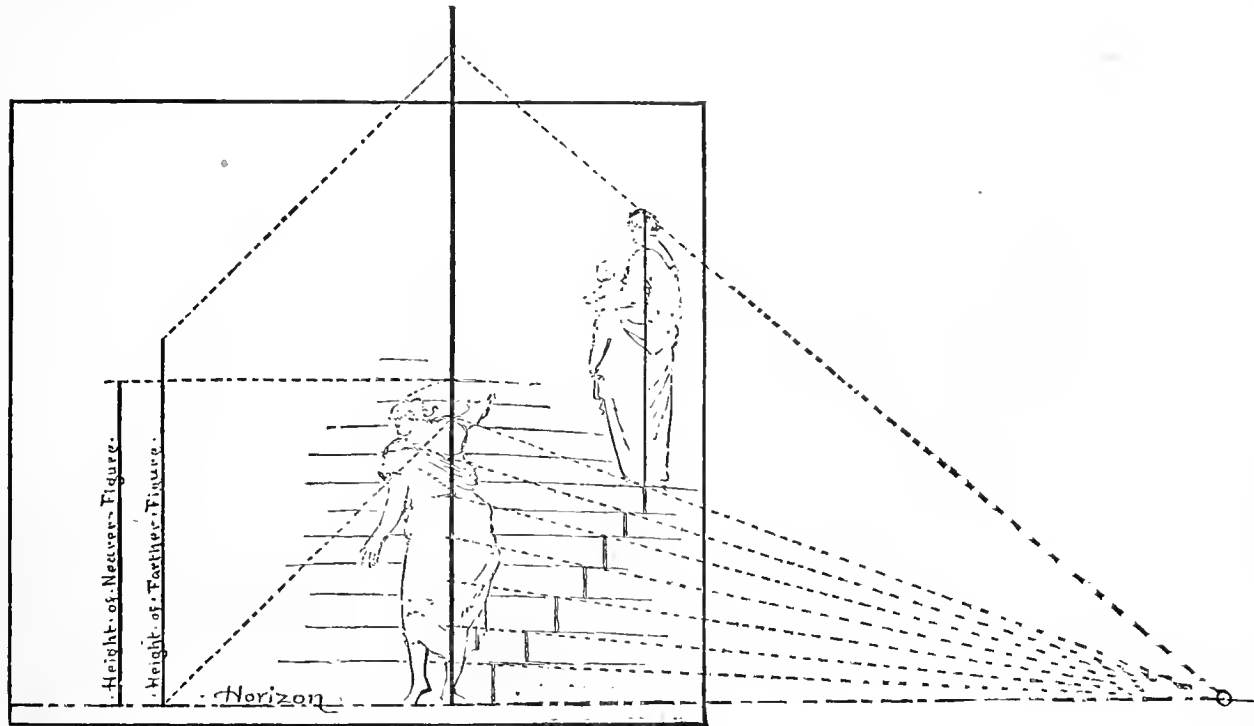

Fig. 39.

look as if the master had been just a little careless in his drawing. In these last illustrations the proposition that parallels between parallels are equal is exemplified only as applied to measuring the *heights* of objects; but the reader will remember that in Figs. 28 and 29 horizontal measurements (the widths of the pathway,

the walls, and the railroad) were determined in the same way. And, indeed, by far the greater number of measurements which the draughtsman ever has occasion to make are made by the application of this very simple rule. Still there are some others in every drawing which have to be determined, if at all, in some other way; and it is mainly because it enables us to accurately determine measurements of the kind which we have yet to consider that perspective is to be dignified with the name of a science at all.

These other measurements, which relate to what is known as "foreshortening," one learns by practice to determine with considerable accuracy by the eye alone; so much so that an artist hardly ever takes the trouble to fix them in any other way, except in the case of subjects where there are very pronounced architectural features. Even the architect soon learns to sketch his building so nearly right that only a few of the more important measurements have to be corrected by mechanical means; but, as the Kentuckian felt about his revolver, which was only for an occasional emergency, the need of knowing how to make such corrections is pressing when it actually occurs.

We will consider this part of the subject in a chapter by itself.

CHAPTER IV.

ANOTHER CLASS OF MEASUREMENTS.—THOSE OBTAINED BY MEANS OF DIAGONALS.

IN approaching the subject of foreshortening, or the measurement of lines which run to a vanishing-point, we find that here, again, it is possible to divide the subject, and to treat the laying-off of actual dimensions—as the length of a house, for instance—in one way, and the dividing of distances already obtained in quite another way ; one, too, that shall be quicker and more convenient.

In Fig. 40 the house, as a whole, was simply “sketched,” which means that the relation of the length to the depth, and of the height to either of the other two dimensions, was determined by the unassisted eye. Whether any one of these measurements is a little wrong or not is a matter of very small consequence, and any error of this kind that may exist in the drawing would probably not be detected, even if the picture were compared critically with the house itself—on the spot ; but an error in the spacing of the windows would be quite a different matter.

There are six openings in each story, set regularly along the front of the house, so that the centre lines of these openings divide the front into seven equal parts ; and the drawing would look badly if these equal divisions did not diminish in regular order as the building recedes from the eye of the observer. All that was necessary, however, was to accurately locate these six centre lines, as the windows may readily be sketched with precision enough after this is accomplished. • This is easily done by means of a diagonal across the house-front.

Everybody knows that if you divide the opposite sides of a parallelogram in the same way—that is, in such a manner that lines connecting the corresponding points in the two divided sides shall be parallel to

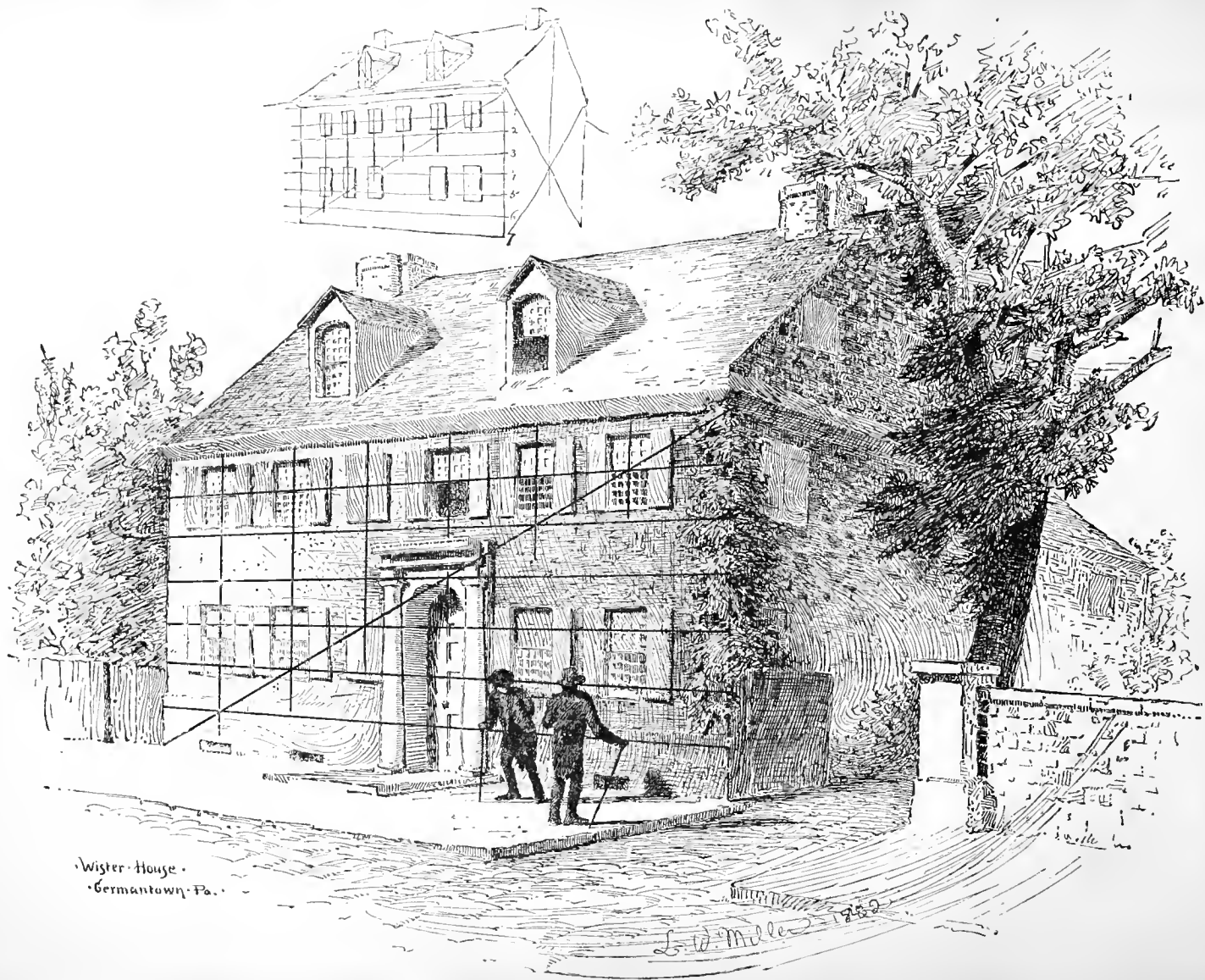

Wister House.
Germantown, Pa.

L. W. Miller 1862

each other and to the other two sides of the parallelogram—everybody knows, or can find out by a moment's reflection, that these parallel lines across the figure will divide its diagonals in just the same proportion as that in which the sides are themselves divided.

Now, in Fig. 40 the two ends of the front of the house are divided into seven equal parts, and lines connecting the points of division divide the diagonal in the same way. Then vertical lines through the points in the diagonal indicate the centres of all the openings. It would have been just as well to divide one end of the house, and to draw the horizontal lines to the vanishing-point, if this had not been so far away that it would have been more inconvenient to use it than it was to divide the other end of the house.

If the centre of the door does not seem to agree with those of the windows in this drawing, it is because the archway projects somewhat beyond the line of the house-front; for this reason the doorway has been omitted altogether in the little diagram, which gives the construction of this illustration by itself.

Measurements may be set off in the same way on any inclined line—the edge of a roof, for example—whether you have occasion to regard it as a diagonal or not. And such lines are often used in drawing stairways, etc., as is shown in Fig. 41.

Divisions of surfaces into any even number of parts are usually made by drawing both diagonals. The diagram in Fig. 40 shows how these were used to locate the points of the gables, those in the dormer windows as well as those in the main roof.

Fig. 42 shows how a surface may be as readily divided into quarters, eighths, etc., as into halves, merely

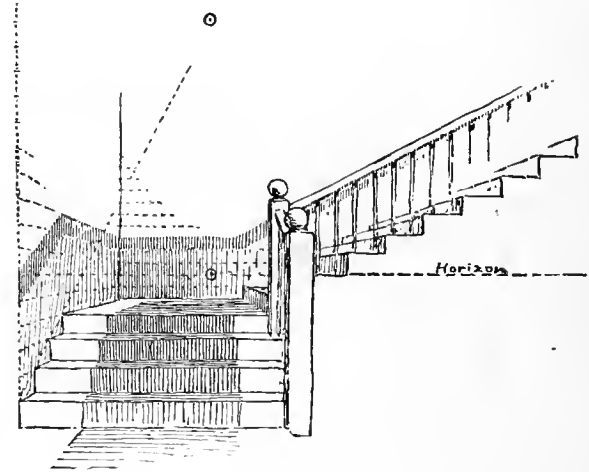

Fig. 41.

by increasing the number of diagonals. Now, as you increase the number of these diagonals, by adding those of the rectangular spaces into which the surface comes to be divided, you notice that these diagonals form other sets of parallel lines which would have their own vanishing-points in the "horizon" of the plane in which they happened to lie. Carry out the three diagonals in Fig. 42, and see if they do not meet in a point which is directly under the vanishing-point of the horizontal lines.

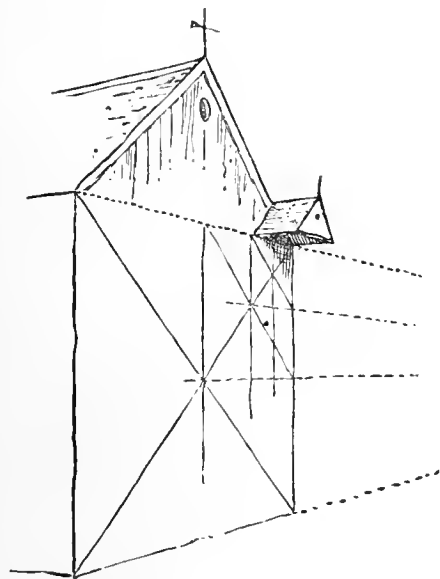

Fig. 42.

We shall find that this vanishing-point of diagonals can be made to do good service in determining measurements, if we only know to what kind of figures the diagonals which vanish there belong.

Suppose, for instance, that you knew the end of the barn in Fig. 42 to be, leaving off the roof, a square. To state it as such would manifestly be the same thing as saying that the lower edge of it, where it rests on the ground, was just as long as either of its vertical edges. So that it might have been measured in the first place by drawing the diagonal from the top of the nearest vertical edge down to the vanishing-point of diagonals, if we had had this point to begin with.

By drawing such another diagonal from the top of the farther vertical edge of the building, you would measure off the same length on the ground-line again, and the operation might be continued indefinitely, or at least until the spaces in your drawing became so small that you could not work any longer. You would always have something left to measure, however, and theoretically you might go on laying off these dimensions forever. The ice-houses in Fig. 43 are measured in this way; the only difference between these measurements and those in Fig. 42 being that the end of each ice-house is twice as high as it is wide, so that each diagonal measures off the width of two houses. A horizontal line across the houses half-way up the ends of them cuts each diagonal in two, as explained on page 35, Fig 40.

The case is just the same when you have horizontal squares to deal with as it is with these vertical ones. You have only to locate on the pavement, floor, ceiling, or any other horizontal surface that may be convenient, a figure which looks *as you think a square ought to look in that position*—one side of it forming part of the line you wish to measure, and another side, which joins this one, lying parallel with the horizon. (Notice that this is the case in Figs. 42 and 43, where the only horizon employed is vertical.)

Do not give yourself any trouble about the proof of this figure being really a square—we will make that all right very soon; just make sure that the opposite sides are parallel—two of them you can draw with a “T” square, and of course the other two will go to the vanishing-point and your square will do well enough. Then draw the diagonal that would correspond to the one used in Fig. 42, and, having carried it

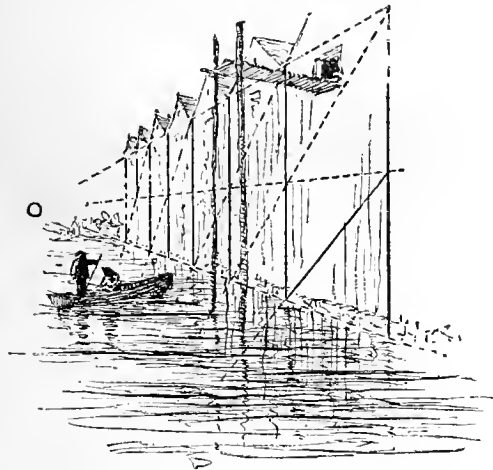

o - Vanishing Point of Diagonals

Fig. 43.

out to its vanishing-point in the horizon, go on with the measuring as in Fig. 43. The process is illustrated in Fig. 44.

The squares employed may, of course, have some connection with the objects represented, or they may be merely supposed to exist in order to serve a temporary purpose in fixing measurements, and the diagonal of one big square may often be made to do the work of several smaller ones; pavements, however large, which are made up of square figures being usually drawn by means of very

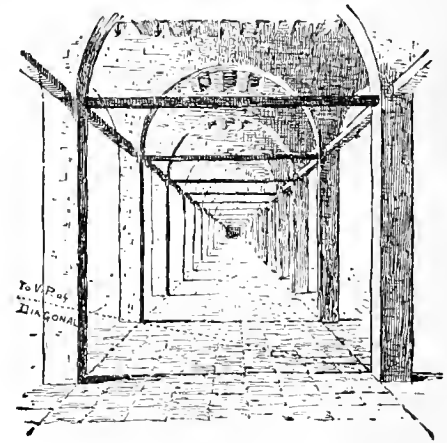

Fig. 44.

few measuring-lines, as shown in Fig. 45. These little squares are often very useful, too, to get larger measurements by; for, supposing their sides to represent feet, or any other unit of measurement, you have only to count off as many of them as you want in order to obtain the distance re-

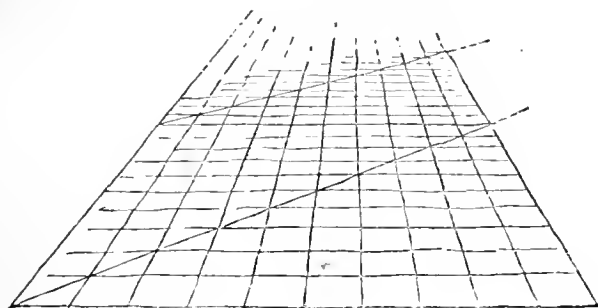

Fig. 45.

quired. Indeed, as we shall see by and by, it constitutes a very convenient and fairly complete "method" of perspective, especially in the case of figure-pictures, to rule off the whole of the ground which is to show in the picture in just such squares as those in Fig. 45, the objects represented being all sketched in with a free hand, as can be done easily enough, the squares furnishing a perfectly accurate scale for any part of the picture.

The location of the vanishing-point of diagonals never need give you any trouble; whatever *looks* right for a pretty good-sized square somewhere in the foreground of your picture will *be* right for the rest of the drawing.

It need never give you even the trouble of being too far away to make its employment convenient, for you can always get as long a measurement as you wish without going beyond the edge of your canvas or paper.

quered. Indeed, as we shall see by and by, it constitutes a very convenient and fairly complete "method" of perspective, especially in the case of figure-pictures, to rule off the whole of the ground which is to show in the picture in just such squares as those in Fig. 45, the objects represented being all sketched in with a free hand, as can be done easily enough, the squares furnishing a perfectly accurate scale for any part of the picture.

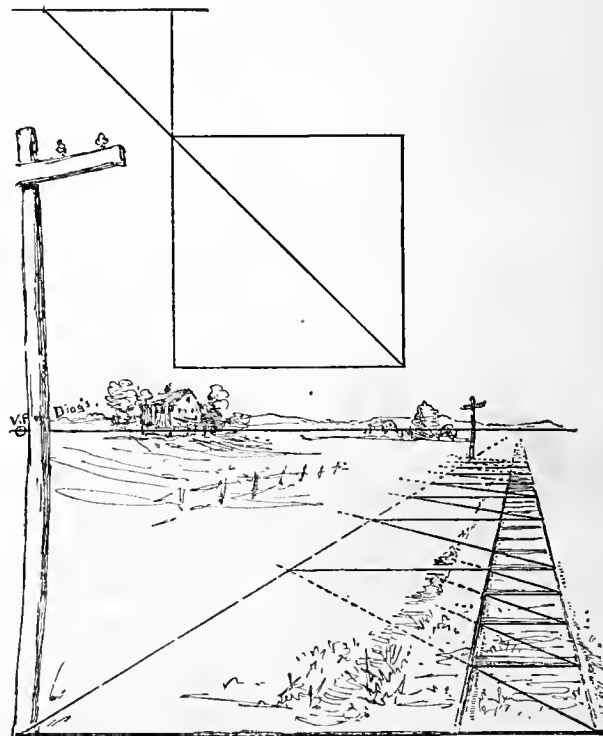

Fig. 46.

The little diagram at "A," in Fig. 47, shows that the vanishing-point of diagonals may be brought as near as you please without changing the result, if you only reduce the measurement with which you begin in a corresponding degree. Compare Fig. 46 with Fig. 47 in this respect. The measurements obtained are just the same in both; but the size of the picture might be reduced to that of the rectangle sketched in the lower right-hand corner of the latter, and even smaller, if found desirable, and the point used to get the measurements by still be kept inside the frame.

The two vanishing-points in Fig. 46 are placed just far enough apart so that the measuring-line is the diagonal of a square, and the measurement with which we begin—the distance from the telegraph-pole to the outer rail—is accurately laid off on the line which runs from one pole to another. If we place the two vanishing-points half as far apart as they are here, then we ought to take only half of our original measurement to obtain the same result. If the distance between the vanishing-points be reduced to one-fourth, make the given measurement one-fourth, too, and the perspective measurement will be just as correct. Or, what is the same thing, you can leave the measurement in the foreground as it is, and then the measuring-line, if drawn to the "half" point, will measure twice as much; if drawn to the "quarter" point, four times as much, and so on. This is what has been done in Fig. 47. Now a word or two about the correctness of the square with which you start. If you will look at Fig. 45 you will see that a square in perspective may

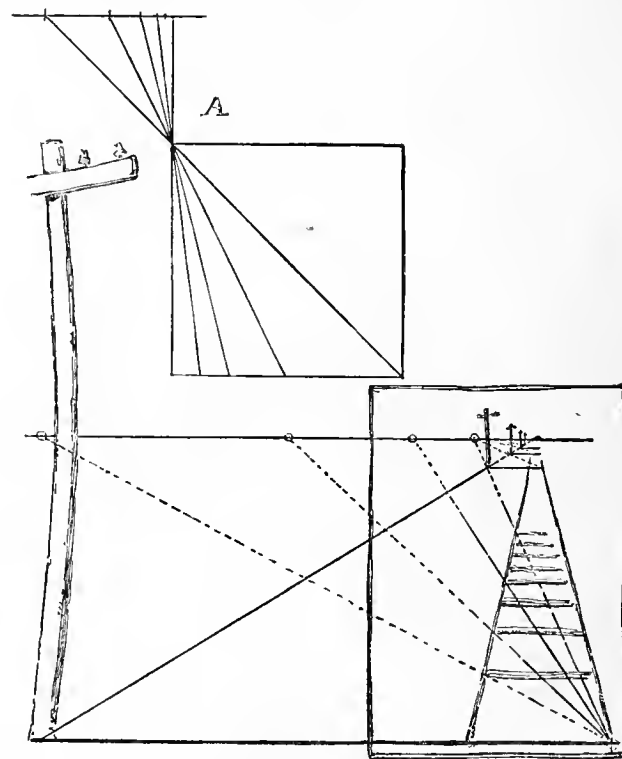

Fig. 47.

look like almost anything that can be formed with four lines, if only the opposite sides are kept parallel (either actually drawn so or vanishing to the same point); and if the figure is somewhat foreshortened—for, as every slab in the pavement, or every stone in the wall (unless the wall face you exactly, and then it can hardly be said to be in perspective), is viewed more or less obliquely, it must, of course, appear somewhat foreshortened—how much it is foreshortened depends simply on how obliquely it is viewed.

Consequently, if you observe the conditions which have just been insisted upon, *you cannot go wrong* in sketching the first square of your pavement or wall—you will in any case make it a possible picture of a perfect square. See Fig. 48.

You may make the square too large or too small; but that is an error which can easily be corrected at any time, and that will not have any influence except on the square itself, for the vanishing-point of diagonals is just the same for big squares as for little ones. Or you may make the square too much foreshortened, or too little; but this is merely a question of appearance, and has no reference whatever to the correctness of the perspective.

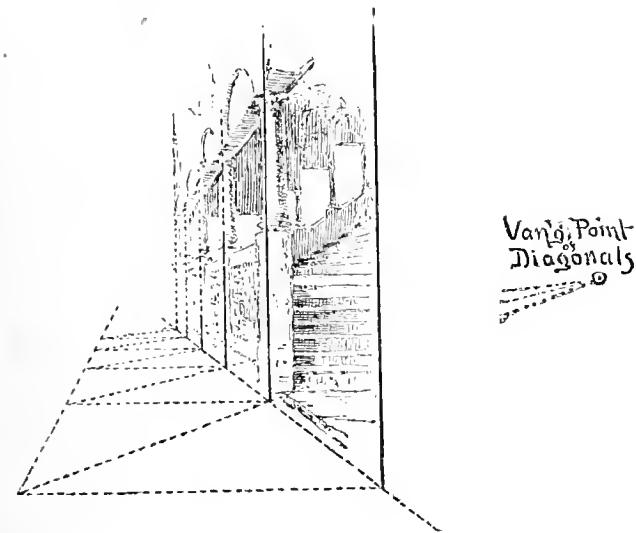

Fig. 48.

For, as the appearance of the square is determined by the observer's position, and as it is a poor rule that will not work both ways, it is equally true that the observer's position is indicated by the appearance of the square.

If you happen to get the square foreshortened more than you intended to have it, the effect will be to make the picture look as if the observer were standing farther off than you intended; that is all, and the contrary is just as true. In other words, the character of this first square, and the general appearance of the

picture, which is determined by it, are purely and simply matters of design, and are always treated as such by architectural and mechanical draughtsmen, as well as by painters.

As a matter of practical convenience, it will be well to make this first square rather large—the whole width of the room or the street, perhaps, rather than a single slab in the pavement—because any slight miscalculation which you might make at the outset, regarding what the final result was to be, will in that case be less and less apparent as you proceed to smaller details, while the same miscalculation in drawing a small thing would be pretty sure to lead to worse and worse results as other and larger objects came to be affected by it.

Observe, however, that, as far as the use of horizontal squares is concerned, this method of determining perspective measurements is only applicable to that kind of drawing which we have learned to know as “parallel” or “one-point” perspective; but where vertical squares are used, as in Figs. 42 and 43, it is just as general a method as any other.

The reason for this limitation is simply this: It is obvious that you can only measure in this way lines that are at right angles to those from which you take the measurements. It has already been insisted upon (page 37), and the proof will, I hope, be clear very soon, that these last must be parallel with the horizon of the plane in which they lie. It follows, then, that the only lines that will combine with these in such a way as to make squares must be those running straight away from the observer, as in Fig. 48. But as any horizontal line is sure to be at right angles to any vertical one, it makes no difference what its actual direction may be. Now for the reason why the line from which the measures are taken, which we will hereafter call the “line of measures,” must always be parallel with the horizon of its plane. All accuracy in work of this kind must depend on our having something assured to begin with. Things which we know to be really of a given size seem to be smaller when they are farther away, and larger when they are nearer the observer; but before we can exactly determine their apparent size in any particular position we must have some standard by which to judge them in all positions—that is, we must have some place in which measurements which are alike shall appear alike.

Your experiments with the screen must already have taught you under what conditions this can happen.

It only happens, you will find, when the line in your picture along which the measurements are taken has actually the same direction as the line in nature which it represents. This is the same thing as saying that real and apparent proportions are just the same only when they are set off on lines parallel with the picture-plane; and being parallel with this plane, they are bound to be *parallel to the horizon of the plane in which they lie*. Prove this for yourself, however, by actual observation.

The windows in the houses across the street seem, as you look out of your window, to grow smaller and smaller as you look farther and farther down the street; but if you set the screen in your own window so that it is just parallel with those in the other houses, you will find that, *measured on the screen*, the windows are all of the same width still.

It is just the same with the vertical distances; but this does not surprise you as the other probably does. There is nothing any more remarkable, however, about one case than the other; the same observations that convinced you, the first time you looked through the screen, that the pictures of such edges of objects as were parallel with the screen must have the same direction as the edges themselves, ought also to have convinced you of this other fact, which is of just as much importance, that measurements along such edges are relatively the same in the picture as they are in the real objects.

And so you see why it is that vertical edges may be divided anywhere, in any way you please, as in Figs. 40 and 43, the geometrical proportions being all right for the pictorial representation of them, and that any measurements that such lines may stand for may be transferred to any horizontal line by this use of diagonals of squares; and if you cannot always feel as sure of horizontal or other lines, or use them in the same way, it is because they are not, as the vertical ones are, always parallel to your imaginary picture-plane—your remembered window-screen. When they are parallel with it, and the lines to be measured are at right angles to them, you can do just the same with them as you can with the verticals.

CHAPTER V.

MEASUREMENT BY MEANS OF TRIANGLES.

IF the method of measuring by means of diagonals of squares is not applicable to every case that can possibly arise in the course of a draughtsman's practice, another and more general statement of what really amounts to the same principle will be found to be so; and as the greater includes the less, this other method might have been described in the first place and all that has been said about diagonals omitted, if the method just explained had not been not only simpler, and for that reason more convenient whenever it was applicable (and it almost always is, as artists use perspective), but being somewhat easier to understand, its discussion beforehand serves a very good purpose. For it establishes, without much trouble, certain points which it is necessary for us to know before we face the more general question.

If in measuring the windows in Fig. 40 it had also been necessary or desirable to determine the exact length of the house itself, the reader will see that we have not yet learned enough about perspective to do it; there is a way, however, of fixing such measures, and this is what we are coming to now.

The width of each window and the length of the house itself in Fig. 49 were fixed in this way—at least they might have been so determined, if the drawing had been made to measure instead of being sketched on the spot.

The line to be measured is, in this case, the ground line of the front of the house. Let us measure its length first and attend to the windows afterward. We have seen (page 41) that any measures we may have occasion to use must be set off, if we are to be sure of them, on some line that is parallel to the picture-plane, and that such a line is always parallel to the horizon of the plane in which it lies; that is, it is always parallel to the original or actual horizon when drawn on level surfaces and always vertical or up-

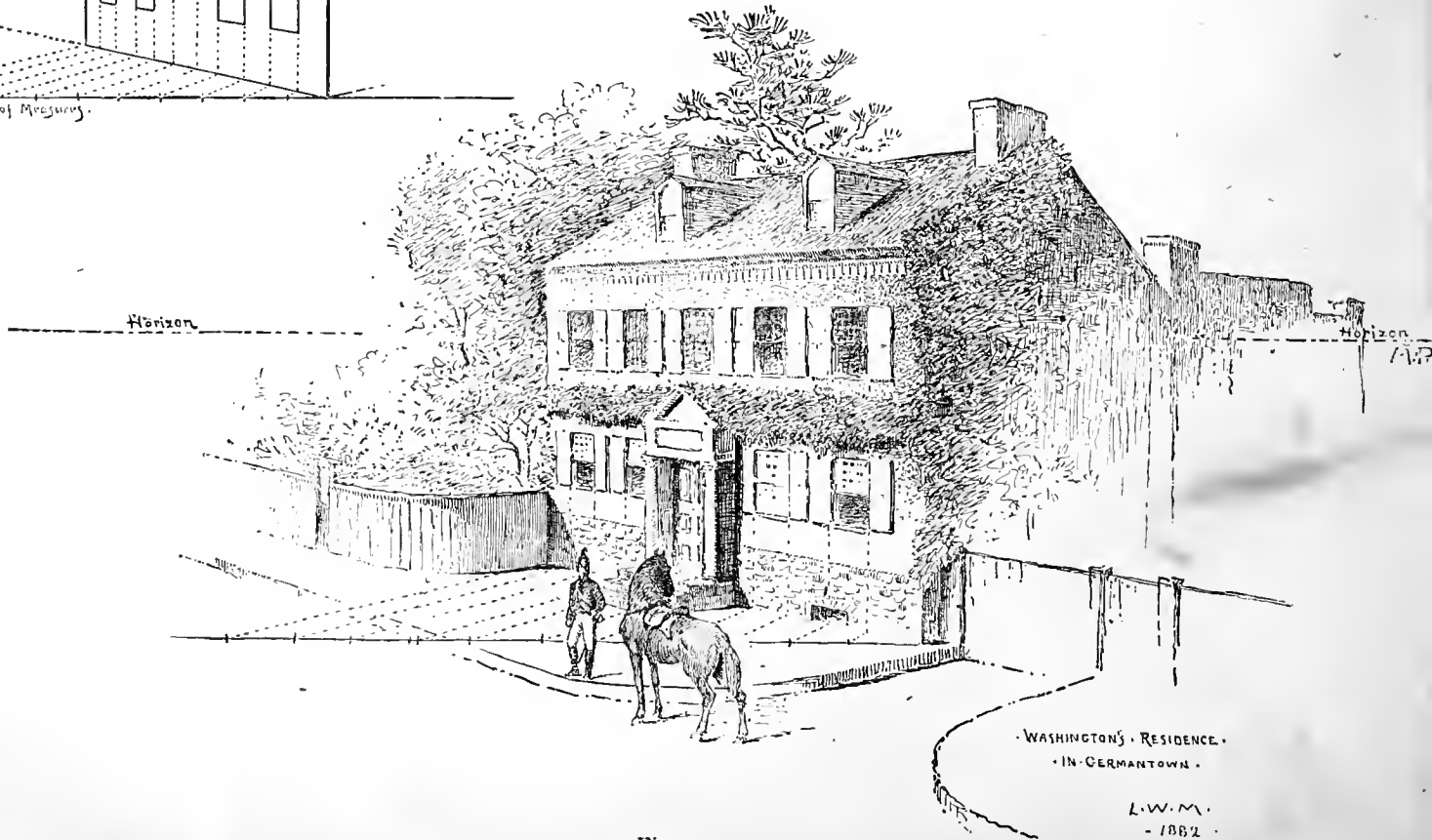
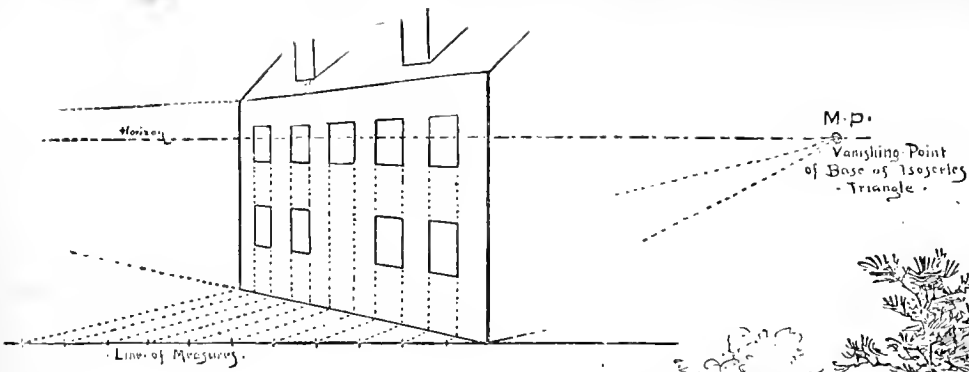

Fig. 49.

right when drawn on vertical surfaces, and so on. Our observations at the screen taught us that long ago. Such a line is drawn, then, in such a position as to have one point in common with the line to be measured. Theoretically this may be wherever you please, but in practice it will usually be most convenient to draw this imaginary line through the nearest end of the line to be measured. As it is never used for any other purpose except to set off measures on, it may be called the "line of measures." In some "systems" of perspective it is confounded with the bottom of the picture-plane and thus becomes a source of endless annoyance to the pupil—and all for nothing, too—for anybody can see that the line has nothing to do with the picture-plane except to be parallel with it. The two things may be, and often are, on opposite sides of the street; indeed, that is just the case with Fig. 49.

The true length of the house, then—that is, its length as compared with its height at the nearest corner—is laid off in a line drawn on the sidewalk through this nearest corner, and parallel to the horizon.

Now, you see that this "line of measures" is just such a one as was used in Fig. 48, only, in that case, it and the line to be measured formed two sides of a square, while now, as they form an acute angle with each other, they can only be regarded as forming two sides of a triangle. But when you think of it, the two sides of the square in Fig. 48 form with the diagonal a triangle too. What, then, is the difference between them? There is no difference, unless we choose to make one out of the fact that in Fig. 48 the triangle has one square corner, while in Fig. 49 the corresponding corner is an acute angle; in every other respect the two cases are exactly alike, and, instead of calling the line which gave us the perspective measurement in Fig. 48 the diagonal of a square, we might just as well have called it the base of an isosceles triangle which had one right angle. Why, then, may we not adopt the same process in Fig. 49 as was employed in Fig. 48, which would consist in making the line to be measured somewhat shorter than the line of measures (for, of course, it would always be a little foreshortened) by completing the isosceles triangle, the equal sides of which the two are supposed to form, by drawing the base; and then, by carrying out the base to its vanishing-point in the horizon and using this point to measure everything else, make the picture consistent, and therefore correct?

We could do so without any trouble or any doubt regarding the absolute correctness of the result if

there were only one face to the building; and, in fact, it is the only really satisfactory way to do, as soon as you know how to reconcile the two sides of the building to each other; so that, when you lay off your triangle on the sidewalk, you know not only that it looks pretty well but that *it must be correct*. It is possible to do this; and its explanation gives the key to the whole matter.

The point which was called the vanishing-point of diagonals in the preceding figures has been called the vanishing-point of the base of the triangle in Fig. 49 (see the little diagram in the corner).

This name is a good one, because it does not allow the student to forget the real significance of the point, something which, as every teacher knows, pupils find it very easy to do; but it is too long, and we shall have to call the point simply "measuring-point"—only do not forget that it always *is* the vanishing-point of the base of an isosceles triangle, otherwise it would not be of the slightest use as a measuring-point. If your picture necessitates the establishing of many measurements, you have to regard it as in good part covered with pictures of isosceles triangles the bases of which all vanish at one or other of these points. Hereafter, then, we will use the term "vanishing-point" (written V. P.) only as applied to the point where the line to be measured vanishes, and call the vanishing-point of the base of the triangle the "measuring-point" (written M. P.); and whenever it is found necessary to use more than one of each it will be well to number them in such a way as to prevent any possible confusion—M. P. 1 to go with V. P. 1, M. P. 2 with V. P. 2, and so on.

In some books on perspective the measuring-point is called by one name in dealing with objects in "parallel" perspective and by another name in other cases; but there is no need of any such multiplication of terms, and in this book no distinction is made in this respect between drawings in which one vanishing-point is used and those in which half a dozen may have been employed.

The location of any measuring-point depends entirely, as we have seen already (page 40), on the position of the observer. It is near the vanishing-point when he is near his imaginary picture-plane (try it with the screen, if you have any doubts about it) and farther off when his eye is more removed from this plane, and except for reconciling the different sides of the building (which we will attend to presently),

you cannot go wrong in placing it anywhere you like: for, to repeat what was said on page 40, with a change which will need no explanation, if you take care to make that side the shortest which you can tell by

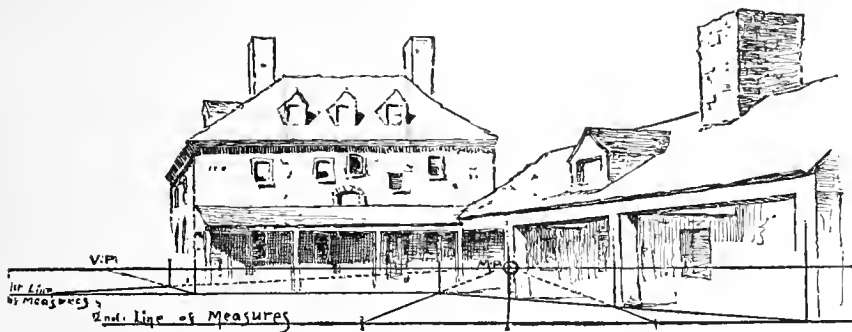

Fig. 50.

looking at it is the one to be foreshortened, you cannot go wrong in sketching your first triangle. Anyone which you may draw on the pavement will be the possible picture of one which is perfectly isosceles. Whether you place the measuring-point too near the vanishing-point or too far away is purely a matter of appearances. Fig. 50 and Fig. 51 represent the same house, and one is just as "correct" as the other; but the distance between the measuring-point and the vanishing-point is very much greater in one of them than in the other. All that is to be said about the result is, that one picture looks rather better than the other.

If it were necessary to explain the difference in the two effects, it would be done simply by stating that in Fig. 51 the observer is supposed to have stepped backward a few paces from the position occupied when Fig. 50 was drawn. But all that the draughtsman need think about is the difference in the effect produced by the two pictures, for that is the really important thing after all. In drawing these two illustrations two "lines of measures" have been employed, merely as a matter of conveni-

ences. Fig. 50 and Fig. 51 represent the same house, and one is just as "correct"

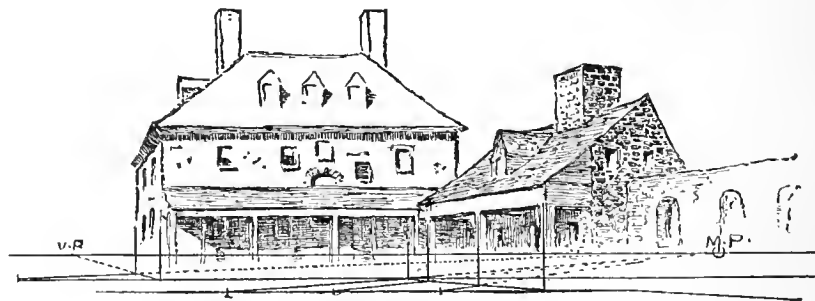

Fig. 51.

ences. Fig. 50 and Fig. 51 represent the same house, and one is just as "correct"

ence. Such lines may be introduced at any corner where they are found to be of use. The main building was drawn first, and as the end to be measured was square, the line of measures at that point is just as long as the height of the corner at which it is placed. In the same way the low building to the right is three times as long as the height of its eaves above the ground, and so *its* line of measures is three times as long as the height of the corner at which it is placed.

The difference in the relative lengths of these two lines, and, indeed, all other differences to be found in comparing the two drawings, arise from the difference in the placing of the measuring-point; for when this is once settled everything else is determined by it.

Now let us see about the relation of the two sides of the building to each other.

Turn back to Fig. 49 and look at the end of the house. You see it has only been sketched, the measurements being guessed at. How, then, do we know that this part agrees with the front of the building and that the whole is in true perspective?

We do not know, but we can very soon find out.

In order to do this with absolute precision, however, and I hope the reader would not be contented with anything less, it will be necessary to analyze the drawing a little, and, by reference to our experimental window-screen, to establish the conditions under which the picture was made.

The conditions are best represented by the screen on which you have been drawing with chalk, but Fig. 52, which is virtually a picture of that contrivance, will do pretty well, and it is desirable to have something in the book to refer to as we go along. The broken glass will answer pretty well in place of the window-screen, and the open box instead of your neighbor's house.

The box is painted on the glass just as it looks to this observer, and its lines having been carried out until they cut the horizon of the picture, the points which are fixed in this way are found to just cover the points on the actual horizon (away out to sea, you know) toward which the lines of the box seem to be pointing.

Only one of these vanishing-points in the actual horizon is shown in the illustration, for the reason that

the other one would be so far away as to make the illustration inconveniently large if it were introduced; but if it were shown, it would be found to bear exactly the same relation to the one in the picture (V. P. 2) as the one which is represented bears to V. P. 1.

The lines running from the box to the observer's eye and to his feet have been used to make the pict-

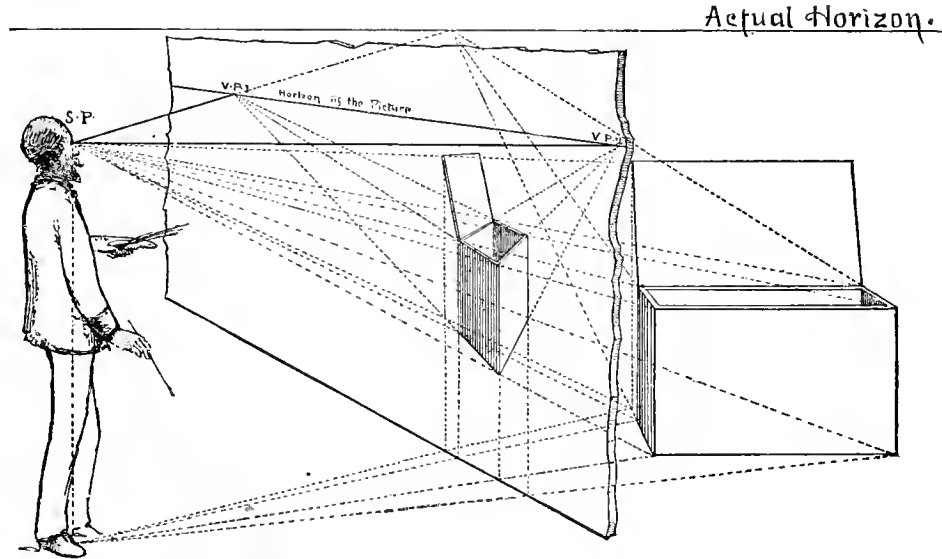

Fig. 52.

ure of the box on the glass accurate. You can make out how this was done if you care enough about understanding it to study the drawing a little, but you need not take the trouble to do so unless you are so minded.

The only thing which it is really necessary for you to know is, that the two lines from the observer's eye (S. P.) to V. P. 1 and V. P. 2 have exactly the same direction as have the horizontal edges of the box itself.

Now, as it is a square-cornered box, these two lines must form a right angle at the station-point. And we shall find that they do so in the picture if we can get such a view of them as will enable us to judge what their true direction is. You prove this easily enough with the bits of thread in front of your window-screen, but we cannot do it quite so readily in this representation of it. If, however, you will take hold of the threads at the station-point and, without allowing them to slacken or change their lengths in any way, will let them turn on V. P. 1 and V. P. 2 as if they were hinges until the threads lie flat on the screen, as shown in Fig. 53, and will then lay the screen itself flat on the table, you will have the same condition of things on your screen that we have in Fig. 54; so that, while the direction of your threads remains relatively unchanged, the picture will now answer just as well as the screen to talk about and make our demonstra-

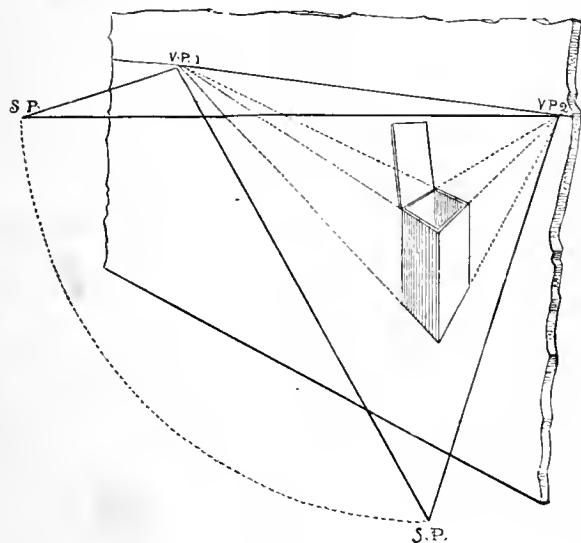

Fig. 53.

tion by.

You will see that on this diagram (Fig. 54) the isosceles triangle which would be used to measure the perspective length of the longest side of the box has been added; its base has been continued to its vanishing-point in the horizon and a line drawn from this point to the station-point, which line, as we have just seen, must be parallel with the actual

base of the triangle. Now, then, we have all the necessary conditions of a perspective problem accurately stated on the paper. It is not by any means necessary that this statement should be based upon actual measurement of the object and its position, as books on perspective usually say it is. But it is necessary, when the correctness of the perspective comes to be demonstrated—to fix the station-point, and to fix it in such a manner that it shall bear the same relation to the lines and points on the picture as that indicated

in Fig. 54. This is not a difficult matter at all, and may be determined without once thinking about the observer's distance from either the picture or the object.

Let us see what the requirements really are. In the first place it is necessary, when you have, as you usually do in representing buildings, a square-cornered object to draw, to have the station-point so placed

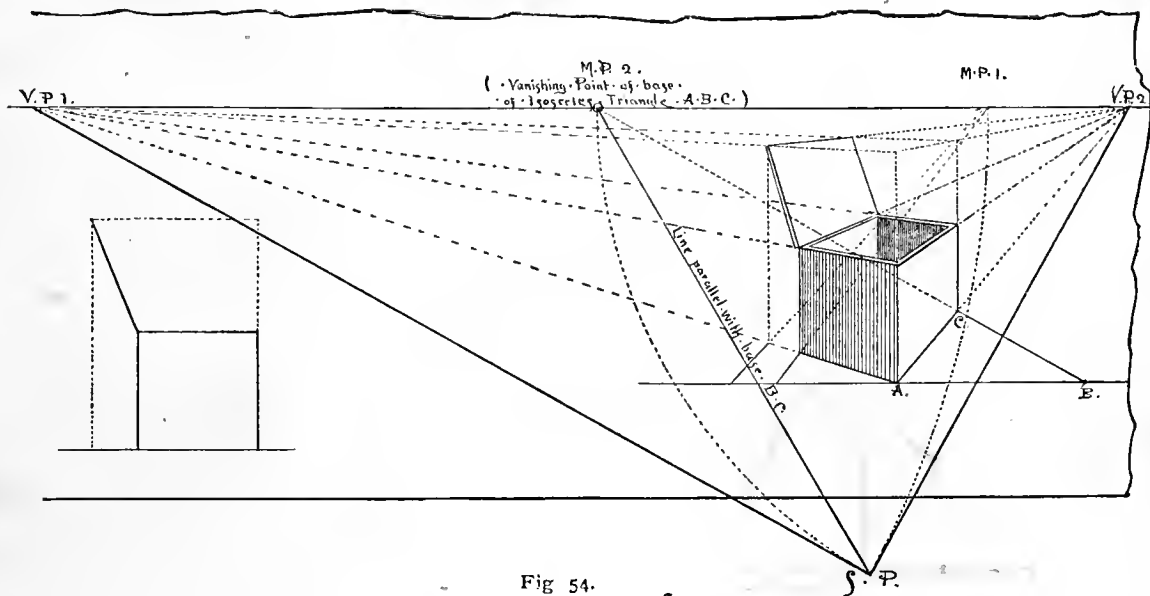

Fig 54.

that the lines drawn from it to the vanishing-points shall form a right angle with each other; and in the second place, *the station-point must be just as far from either vanishing-point as the corresponding measuring-point is.*

You see that this will always have to be so because, as the horizon of the picture is parallel to one side of the isosceles triangle on the pavement and the lines from the station-point are parallel with the other two, the

three lines on or in front of the picture must form an isosceles triangle also,* and that the line to the measuring-point is the base of it, so that the other two must be of the same length. This is the whole story, and if we adjust any drawing which we may happen to have in hand to

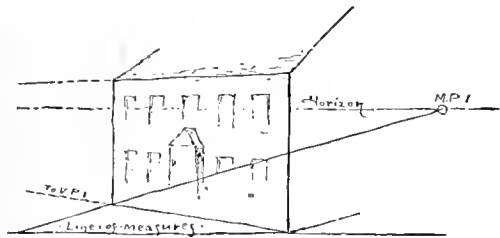

Fig. 55.

these conditions we need not have any doubts about its correctness. Let us turn back and do this with the house in Fig. 49. I have said that it is possible to draw one side of the house without going into the questions which we have just been discussing. Suppose we draw the side which is measured in Fig. 49, fixing the measuring-point at random and making the line of measures represent the known relation between the height of the nearest corner and the length of the house, with the result shown in Fig. 55.

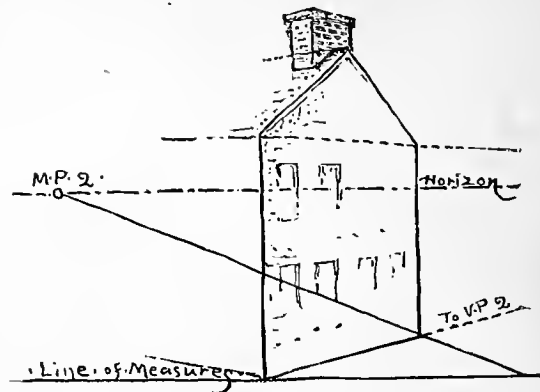

Fig. 56.

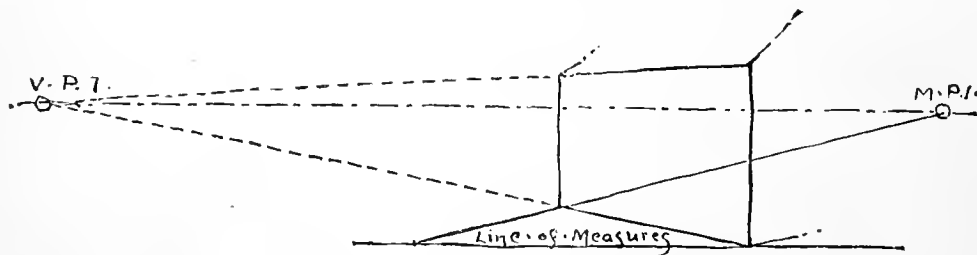

Fig. 57.

Now this *may* be a perfectly accurate measurement for this side. Next let us draw the other side by itself, as in Fig. 56, which, considered by itself, may be perfectly accurate too, although the measuring-point

* According to the familiar truth, "If the three sides of a triangle are parallel to the three sides of another triangle, each to each, the triangles are similar."

was taken just as much at random as the other one was. Now let us see if they will go together as they

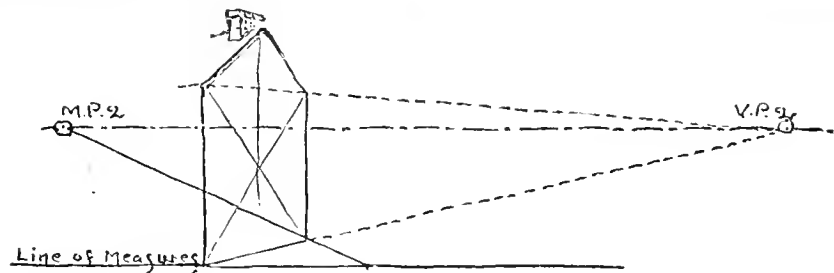

Fig. 58.

ought. Carry out the lines in the first one to their vanishing-point as in Fig. 57, and those in the other as in

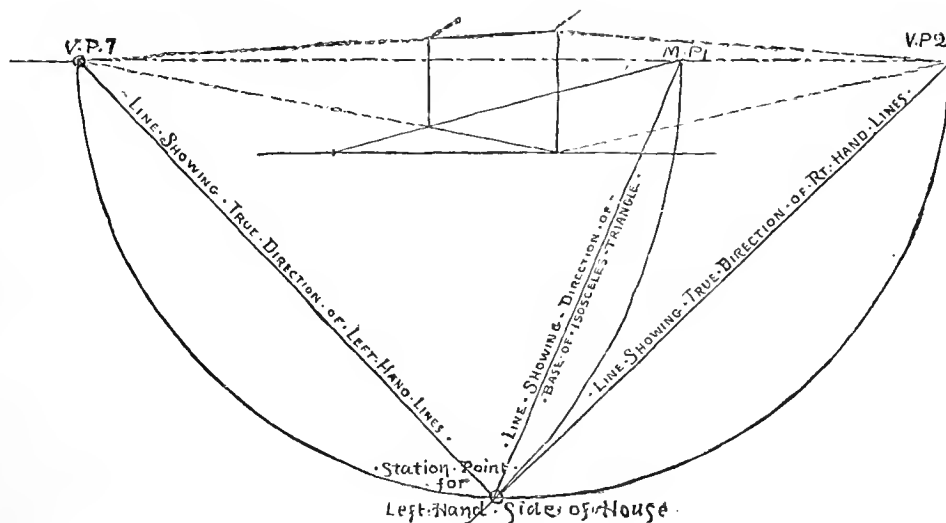

Fig. 59.

Fig. 58. The nearest vertical line in the house being common to both drawings, you can readily determine

the position of the vanishing-point which remains to be found in either case by measuring its distance from this line along the horizon. Do this, and establish both vanishing-points on both drawings, as in Fig. 59 and Fig. 60. Having done this, it will be easy enough to fix on each picture the station-point as it would have to be in order to have the picture look as it does. For, as the corner of the house is a right angle, and as

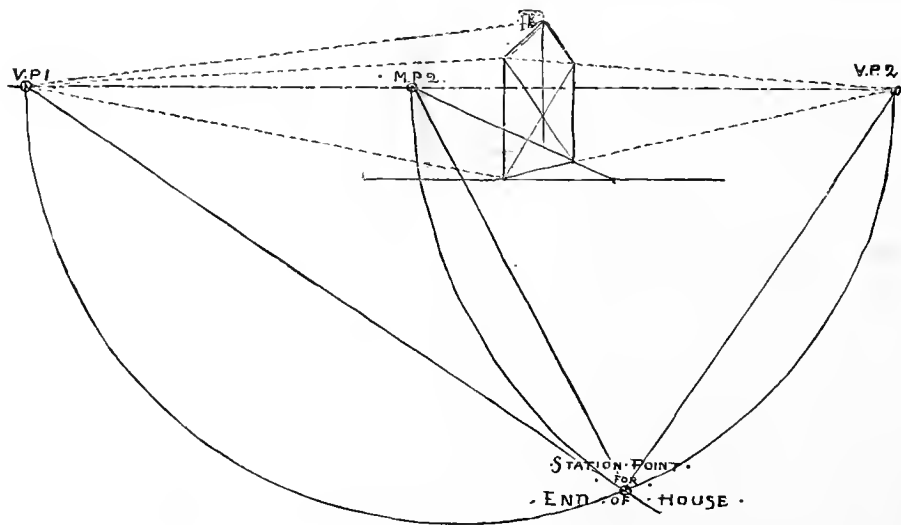

Fig. 60.

everybody knows that any angle inscribed in a semicircle is sure to be a right angle (if he has any doubts about it he must brush up his geometry to the extent of satisfying himself), we have only to draw a semicircle connecting the two vanishing-points, and are sure that the station-point must be somewhere in this. Then as we know that the station-point is just as far from the vanishing-point as the measuring-point is, we lay off this distance on the semicircle with the compasses, and that gives us all we want to know. All the

points that could possibly be used have been established, and the accuracy of our original sketch may be demonstrated to our heart's content.

Now let us put the pictures of the two sides together and see if they agree; that is, let us see if the point from which each side must have been seen to look like this would be right for the other side too. If

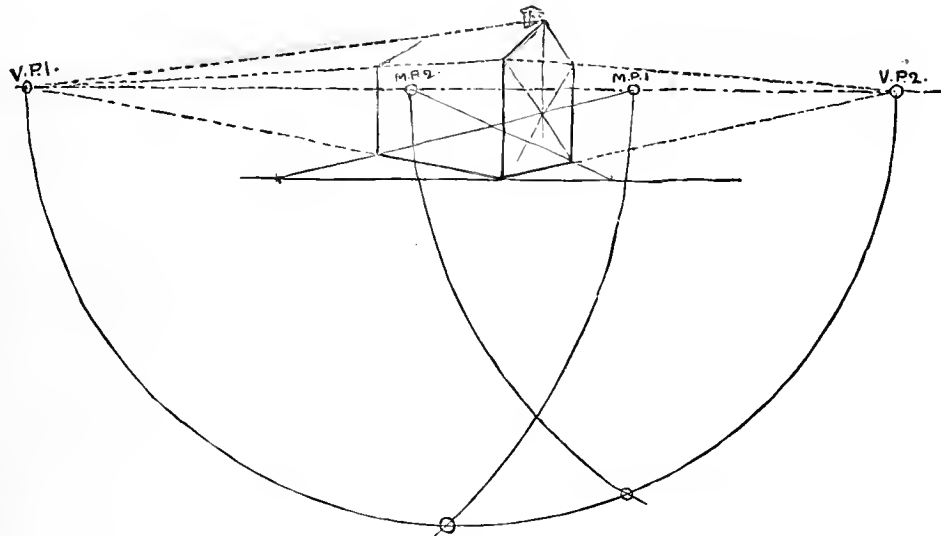

Fig. 61.

you make a careful tracing of either drawing, and apply it to the other, you will obtain the result shown in Fig. 61, which is as complete a *reductio ad absurdum* as anyone could wish, for the station-point certainly cannot be in both these places at once. To correct the drawing of the house as a whole, it is necessary either to retain one of these station-points, and, leaving one-half as it is, make the rest of the drawing conform to it, or to take a new station-point altogether.

This last is usually the best way, because, by taking the station-point about half-way between the two, you do less violence to your original design than would result from the other course. This form of correction has been applied here, and the result is shown in Fig. 62.

Of course, if the base of the triangle measures the whole object correctly, lines parallel to the base will

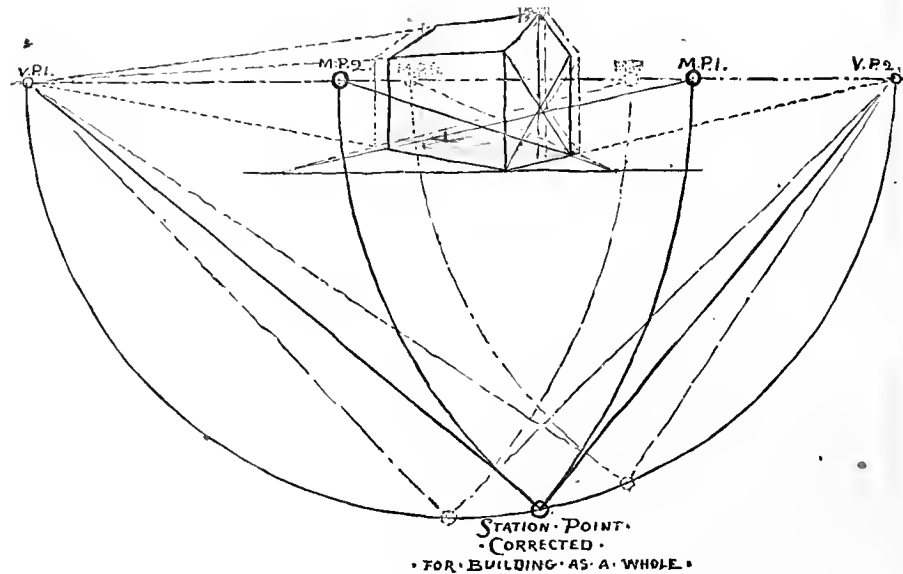

Fig. 62.

measure any details and divisions just as correctly, so that nothing more need be said about the windows in Fig. 49; and as it makes no difference whether the triangle is horizontal or vertical, this method may be applied to such lines as those in the roof in Fig. 63, just as well as to the horizontal lines of the house.

If you should have occasion to make the corner of a building something else instead of a square one,

you can always manage it by comparing it with a square corner, as will be explained in the chapter on curves, or you will see in the chapter on methods a way of drawing any kind of a figure, no matter how irregular, by an easy application of the principles of parallel perspective.

I have a suspicion that, in spite of all my assurances about the correctness of the squares, imaginary or other, on which we have learned to depend for a large part of our perspective measurements, a good many readers will still be haunted by doubts about them. How do we know, they may have said to themselves more than once already, that the end of the house on page 47 was really square after all? Why may it not have been an oblong pretty nearly square, perhaps, but still not quite equilateral?

The figure which was sketched on the ground to start the measuring by may have been a square, but it may also have been an oblong, and had we wanted it to be one we should have drawn it in precisely the same way. How, then, shall we know which one our drawing represents? Our experience with the two sides of the house in Fig. 49 will help us out in this case as well.

Every square has two diagonals, which cross each other at right angles. And anybody can see, by looking at the diagrams which we have just been using, that if the one diagonal used in Fig. 50 vanishes where it does in M. P., the other one would vanish just as far to the other side of the vanishing-point at the end of the house (V. P.); and, having found the vanishing-point of the other diagonal, we could locate the station-point in this case in very much the same way as we did in the other (see Fig. 62). Then we should be able to prove that the picture of the end of the house represented a perfect square, as seen from this station-point.

Seen from any other it would, of course, represent an oblong just as correctly, and we could determine the precise character of the oblong just as well as we can demonstrate the squareness of this figure, if we had accurate data concerning it. For the lines which meet in the station-point, as they stand for the actual directions of the diagonals of the figure represented, must meet at the same angle as that at which the diagonals

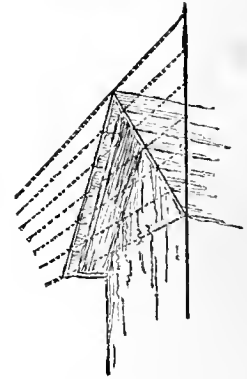

Fig. 63.

cross. Knowing what this angle is, we could locate our measuring-points and set off the length of the sides of the oblong just as correctly as we have those of the square.

One word more about the station-point in Fig. 50, and we are done. I said we could locate it in "very much" the same way as we did the one in Fig. 62. Very much, but not quite. Very much more readily, perhaps, but in a way that may require a little explanation, all the same.

Suppose we had found both measuring-points in this illustration, then one of them would be just as far to one side of V. P. as the other one was to the other side; which is the same thing as saying that the observer must be standing directly in front of V. P. Satisfy yourself about this, if you have any doubts, either by looking at the picture or by experimenting with your screen. The station-point, then, must be in a semicircle connecting the two measuring-points and must be directly opposite V. P.

The distance from V. P. to the station-point will, you see, be just the radius of the semicircle, and if our drawing had been based on assumptions of actual distances, or even on real measurements instead of on appearances, we might have set down our V. P. anywhere; laid off the line to the station-point of the right length; drawn our semicircle, and so on, and this is the way it is often done.

CHAPTER VI.

THE PERSPECTIVE OF CURVES.

THE reader understands by this time how much easier it is to draw squares, or at least rectangular figures, in perspective than any others; and, as a matter of fact, everything else is usually drawn by means of such figures. It is usual, for instance, to enclose a circle or any other regular, curved form in a square, as in Fig. 64, or in an oblong, as in Fig. 65, and, having drawn these last in perspective, to note where the curves touch their sides or cross their diagonals, and to locate these points by means of

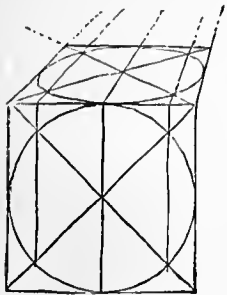

Fig. 64.

parallel lines running into the picture at the right distance from the sides. You can in this way obtain as many points as you need, and can then sketch the curve through them accurately enough.

In the case of the circle as shown in Fig. 64, it makes no difference whether the square is in "parallel" perspective or not; the result will in any case be an ellipse and it will always be a *level ellipse*, if the circle represented is level in reality and is directly

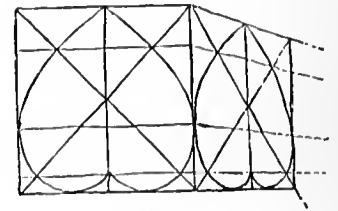

Fig. 65.

in front of the eye. Figs. 66 and 67 show a circle above the eye drawn in squares in different positions, but the results, as you see, are precisely the same.

A good deal of energy has been wasted in curiously childish discussions as to whether the perspective of a circle really was an ellipse or not, and in some drawing-books you will find the circles all drawn wrong.

The discussion is not worth reviving, but anyone who has any doubts about how a circle appears may very soon convince himself by working out a few very elementary problems in conic sections. For the pict-

ure of a circle (unless it is seen edgewise, when it appears as a straight line, as any other plane figure does) is a section of a cone of which the circle itself is the base and the eye the vertex. Figs. 68, 69, and 70 may

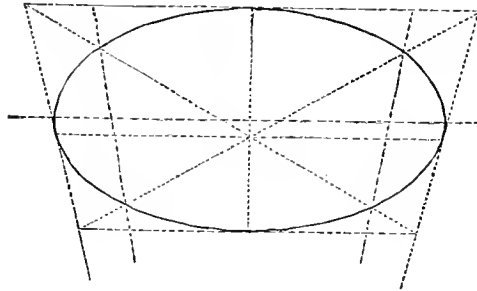

Fig. 66.

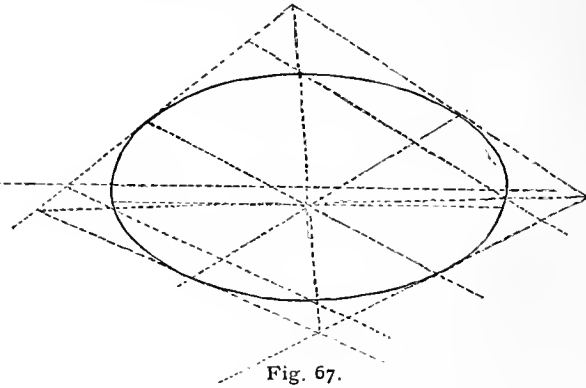
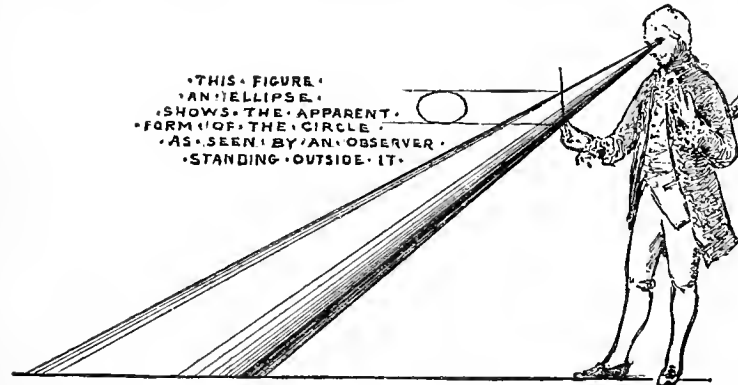

Fig. 67.

help the reader to remember under what conditions a circle in perspective, or any part of one, becomes

any kind of a curve other than an ellipse. It is, I hope, not necessary to say, that when the circle is vertical and parallel with your picture-plane, the representation if it is still a true circle, as shown by the cart-wheel in Fig. 1. But in any other case where the whole circle can be seen in the picture, it appears as an ellipse.



• THIS FIGURE •
• AN ELLIPSE •
• SHOWS THE APPARENT •
• FORM OF THE CIRCLE •
• AS SEEN BY AN OBSERVER •
• STANDING OUTSIDE IT •

Fig. 68.

picture is a hyperbola. Remembering this, the student will always sketch his circle accurately enough if he fixes the width of his ellipse as compared with its length by first drawing a square in the place where it is to go.



Fig. 69.

THIS LINE
A PARABOLA
SHOWS THE APPARENT
CURVATURE OF THAT PART
OF THE CIRCUS RING WHICH
IS SEEN THROUGH THE HOOP
BY AN OBSERVER
STANDING ON THE RING

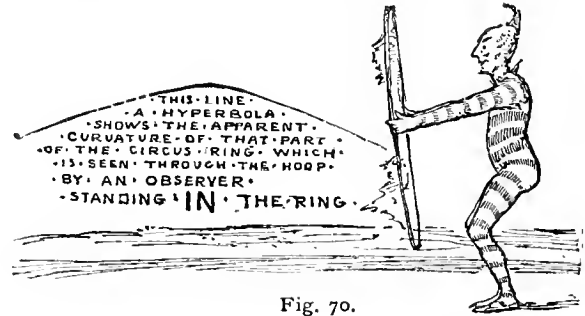

Fig. 70.

THIS LINE
A HYPERBOLA
SHOWS THE APPARENT
CURVATURE OF THAT PART
OF THE CIRCUS RING WHICH
IS SEEN THROUGH THE HOOP
BY AN OBSERVER
STANDING IN THE RING

wheels, of the under side of arches, etc. If drawn at any considerable distance above or below the eye, and at the same time to the right or left of it, the ellipse will look "askew" as it does in Fig. 72, the major axis

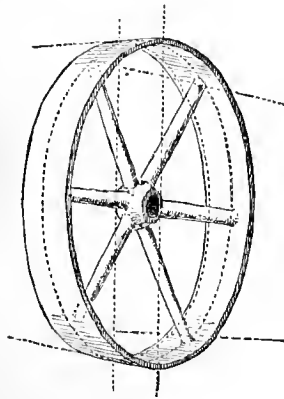

Fig. 71.

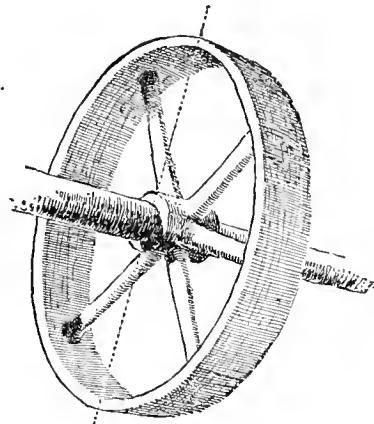

Fig. 72.

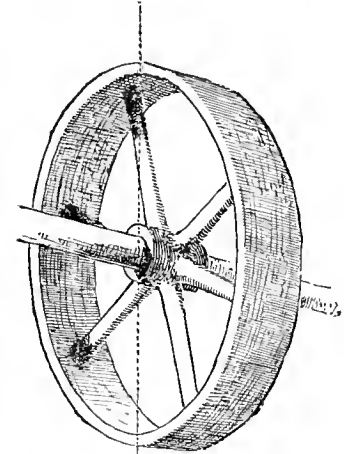

Fig. 73.

of the ellipse being at right angles to the axis of the wheel or other cylindrical body with which it may be

associated. Disliking this effect, draughtsmen sometimes take a little liberty with the perspective, and “straighten up” the ellipse as in Fig. 73. This often has a good effect, and indeed seems to be almost necessary in the case of horizontal circles, such as the tops of columns and towers, but it is of doubtful utility as applied to vertical circles, as the reader will admit who compares the two drawings of a pulley given in Figs. 72 and 73.

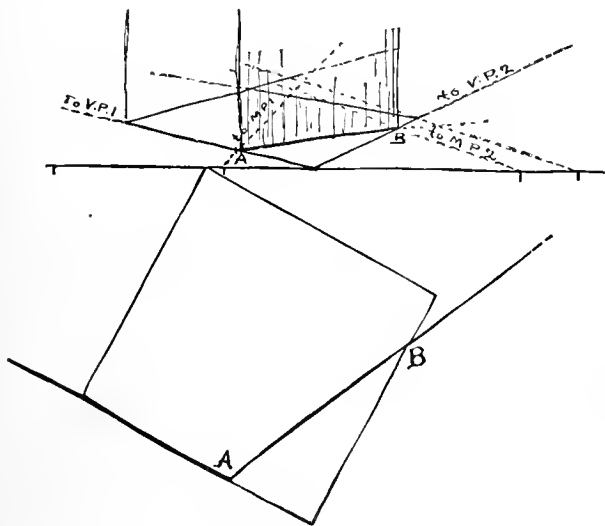

Fig. 74.

Sometimes, however, in drawing the under side of arches the effect of the true perspective representation is decidedly offensive, and the error, for such it really is, of drawing a vertical ellipse instead of an oblique one, has to be introduced. Whether to do so or not is a question for the draughtsman’s good sense—artistic sense—to determine.

Angular figures, other than rectangular ones, may be drawn in the same way as those which are bounded by curves, by drawing square or rectangular shapes around or through them and measuring on the sides of the latter the points where the other figures touch, or cut them.

The obtuse angle of a building, for instance, as at A, Fig. 74, might be drawn easily enough by means of the square. You have only to draw the square in perspective

and measure off the points A and B on its sides, so that you do not need to trouble yourself to find either the vanishing-point or the measuring-point of the line AB. A better way, however, to do anything of this kind will be found in the chapter on methods.

CHAPTER VII.

A QUESTION OF METHODS.

AN artist's knowledge of the mathematics of perspective is a good deal like a poor man's money in the savings bank. He wants to be sure of it, and is anxious about it if he is not, but he has little use for it from day to day. Occasionally he makes a little draft upon his capital fund to help him out of some immediate difficulty, but the bulk of his fortune may, and ought to, remain untouched most of the time.

But it is different with the architect or the mechanical draughtsman.

Plans and elevations drawn to scale have, in their case to be transformed into perspective representations by a more or less mechanical application of the principles which have been considered in the preceding chapters. There are several different methods, fairly distinct, of making this application. Which one is most convenient in any particular case the draughtsman's own judgment must determine.

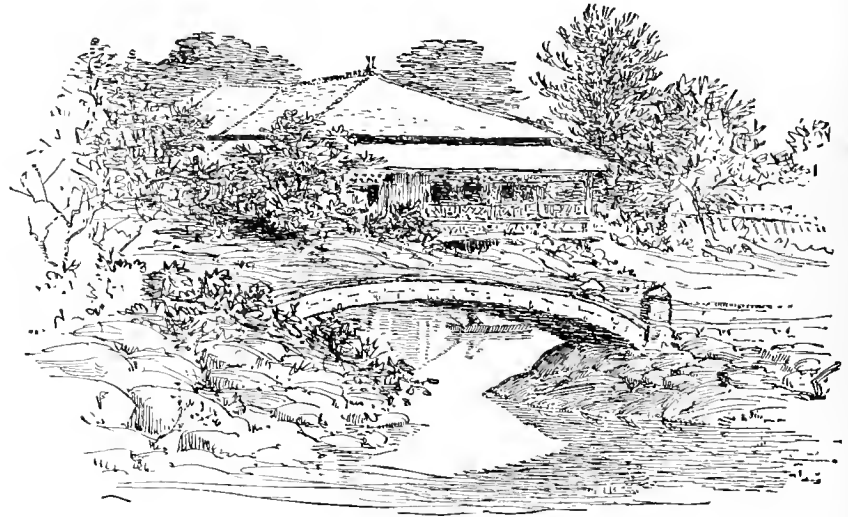

Fig. 75.

The one to which the most prominence is usually given in elementary works, of assuming the horizon, the station-point, and the size and position of the object, arbitrarily, and letting the effect take care of itself, is the most mechanical, and least satisfactory.

The better way usually, is to make a free-hand sketch, giving, as nearly as possible, the proportions of the object and indicating, at any rate, the *desired* effect. By going over this sketch, as Fig. 49 was gone over

in a preceding chapter, the necessary data for an accurate drawing are easily and quickly obtained, and the draughtsman has the satisfaction of seeing the result something like the one intended, a thing which he is by no means sure of when working in the other way.

The draughtsman who has ever had occasion to construct some such drawing as that shown in Fig. 77, having no other data than those furnished, let us say, by a photograph looking something like Fig. 75, taken from another point of view than one desired, and encumbered with shrubbery which he wishes to leave out, and

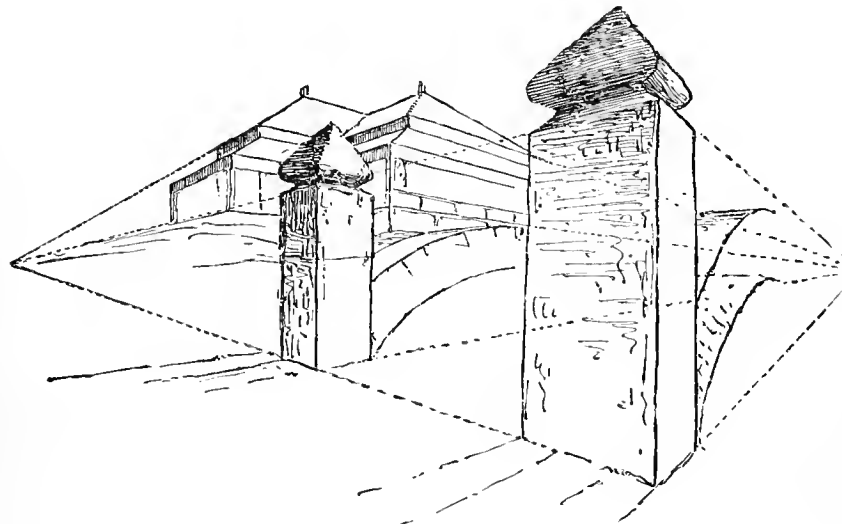

Fig. 76.

who, after much plotting and planning and "assuming" of station-points, has obtained a result something like that in Fig. 76, finds little consolation in the certainty that his production is in true perspective.

Fig. 77 is just as correct, and looks a great deal better, simply because it was made over a sketch which was approximately right to begin with.

But even when this point regarding the general method of procedure is settled, there are different ways of going about a drawing, some of them being best suited to one class of work and some to another. The draughtsman's own good sense must determine which method is best in any particular case.

You may, if you choose, find the vanishing-point and the corresponding measuring-point for each set of lines in your drawing—the oblique ones, as well as those which are horizontal or vertical—or, by referring to your elevation and plan, you can reduce everything to a question of relative heights and of measurements on the ground. As heights are always the easiest measurements to determine—no other calculations than those apparent at a glance in any of the first illustrations used in this book being required—it will not be necessary to say any more about them.

Confining ourselves, then, to the dimensions measured on the ground or floor, we shall see that it is always possible either to draw and measure each line by itself, involving the use of just as many vanishing-points as there are directions, or, by establishing a certain number of measurements on lines which run directly into the picture, fix all the *corners* separately, it being an easy matter to connect them afterward without regard to where the lines connecting them would vanish. This method has the double advantage of enabling you to represent objects in any position, without going outside the limits of your picture to find vanishing points, and to locate any point by reference to your geometrical plan or elevation alone, without regarding the rest of the picture. Fig. 78 has been drawn in this way, each corner of the ground-plan being located by itself by means of one measuring-point (the vanishing-point of diagonals of the square), and each

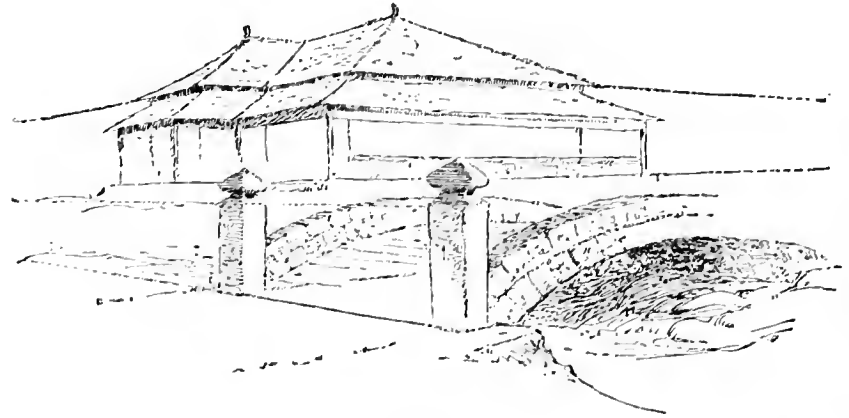

Fig. 77.

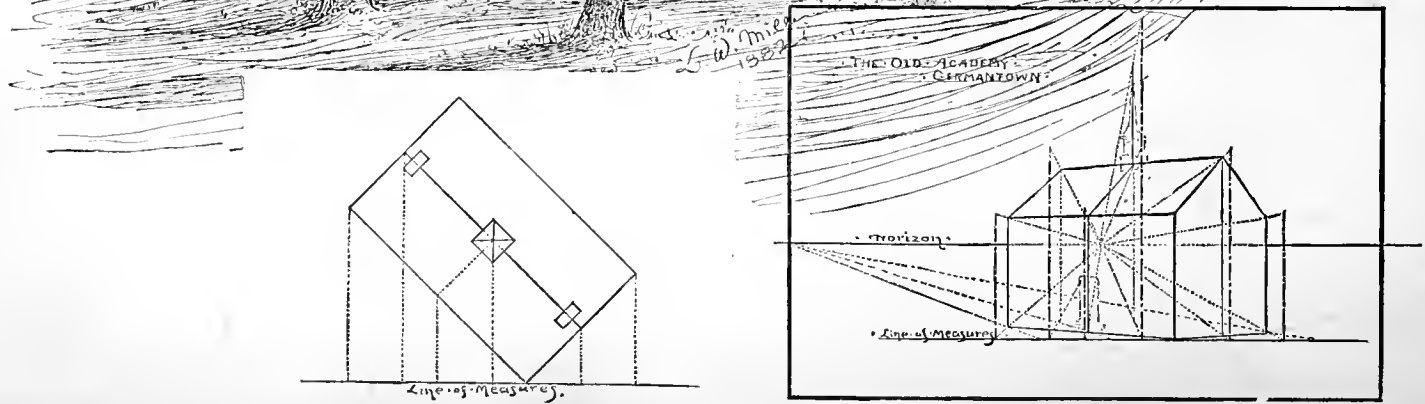
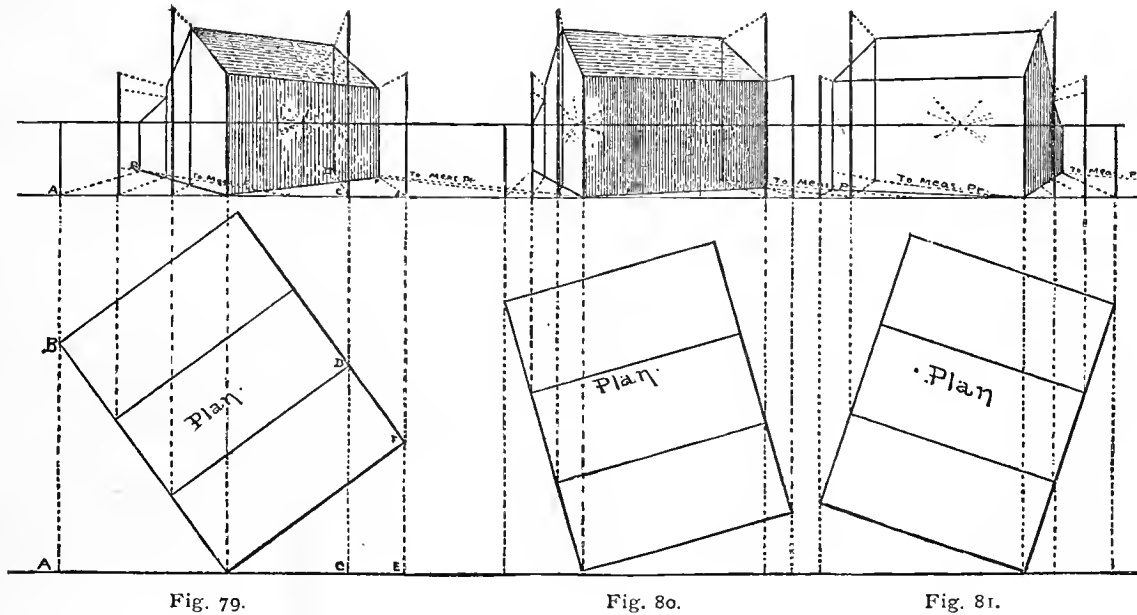

Fig. 78.

height measured separately by means of the one vanishing-point. This brings the whole subject down to a question of "parallel" perspective, as you see, and to using the one vanishing-point which we have learned (Chap. I.) to call the centre of vision. Remember, however, that this does not mean that the point



is necessarily in the middle of your paper or canvas, but only that it is supposed to be directly in front of the observer's position, and so the *centre of all that he sees*.

Another advantage to be derived from employing this method is, that you can try different effects by varying the position of the geometrical plan, as shown in Figs. 79, 80, and 81—the necessary data being furnished by the plan and elevations, Fig. 82, and each height established as in Fig. 83. Only, of course, it makes no difference in this last operation whether the line showing the real height is set up at A and the

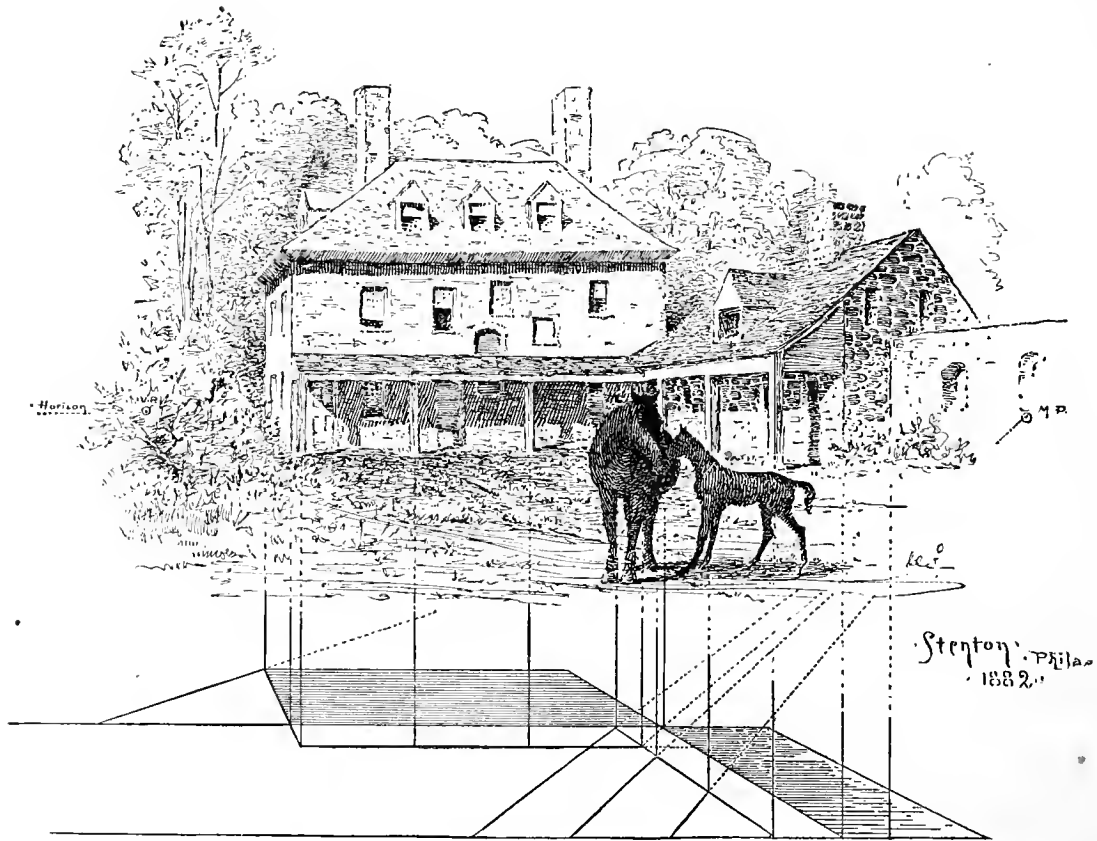

Fig. 84.

parallels drawn to CV, or the height given at B and the parallels drawn to the measuring-point; all that is necessary being that parallels should be measured by parallels. If the reader objects that in these cases the measuring-point comes a good way off, he is reminded that he can bring it as near as he likes by remembering what was said on page 39 and illustrated by Figs. 46 and 47.

Another good way to do, and one which will be found more convenient than the last when the plan is at all complicated, is to measure off the edges of the ground plan by means of the vanishing-point and the measuring-point belonging to each set of lines, but making the measurements much easier to fix by putting them well below the object.

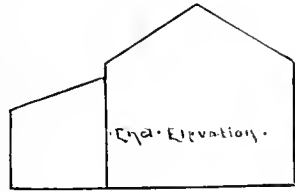
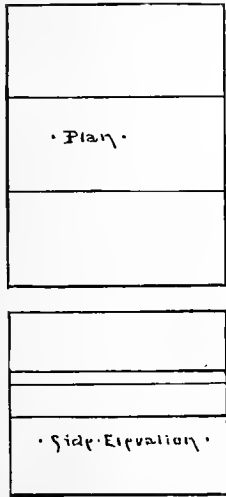

Fig. 82.

If the reader will turn back to Fig. 51 he will understand the significance of this. The measuring here is all done within such narrow limits, and the lines cross each other at such sharp angles, that it requires great care to make the drawing accurate.

It would have been much more convenient to put the measurements well out of the way, by extending the vertical lines downward and constructing a perspective plan, as has

been done in Fig. 84. In architectural work this method has the advantage, also, of allowing any number of alternative treatments of the building to be represented without the trouble of redrawing the plan every time; for this can be on another piece of paper, if you like.

In case the multiplicity of roofs of such subjects as this should ever give the student any trouble, the construction of dormers is explained in Figs. 85 and 86. The first one applies to such dormers as are shown in this illustration (Fig. 84), where only one vanishing-point is used, and the other one shows what to do in case you have to employ more of these points.

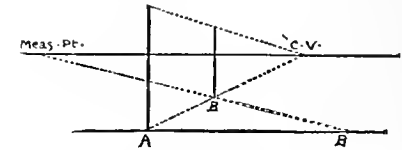

Fig. 83.

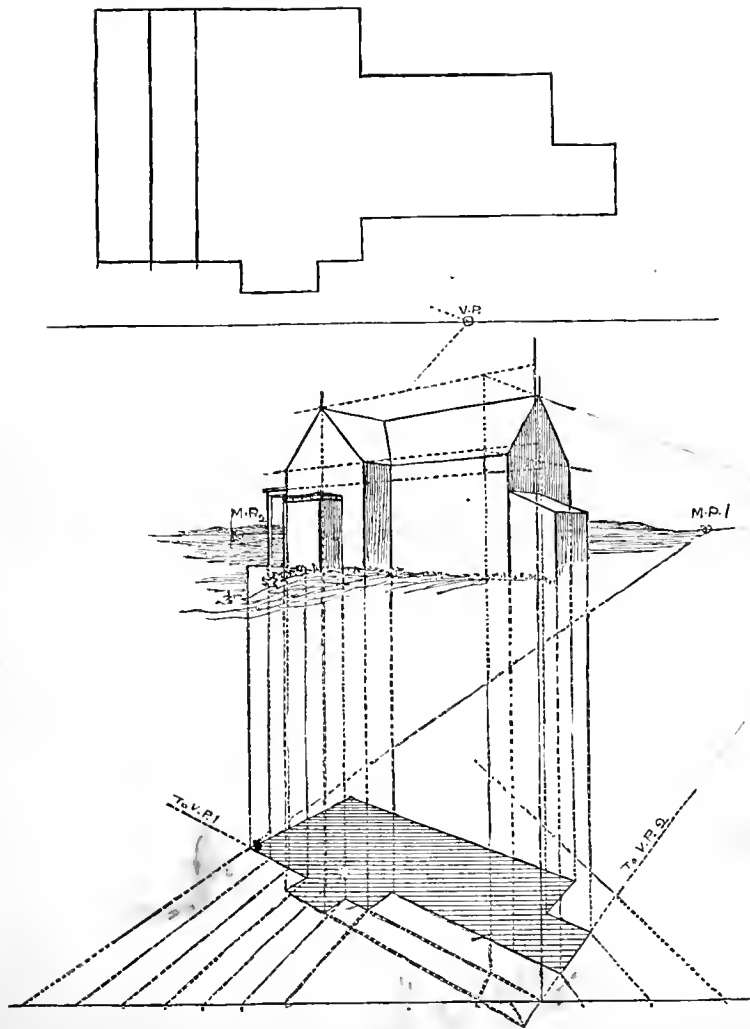

Fig. 88.

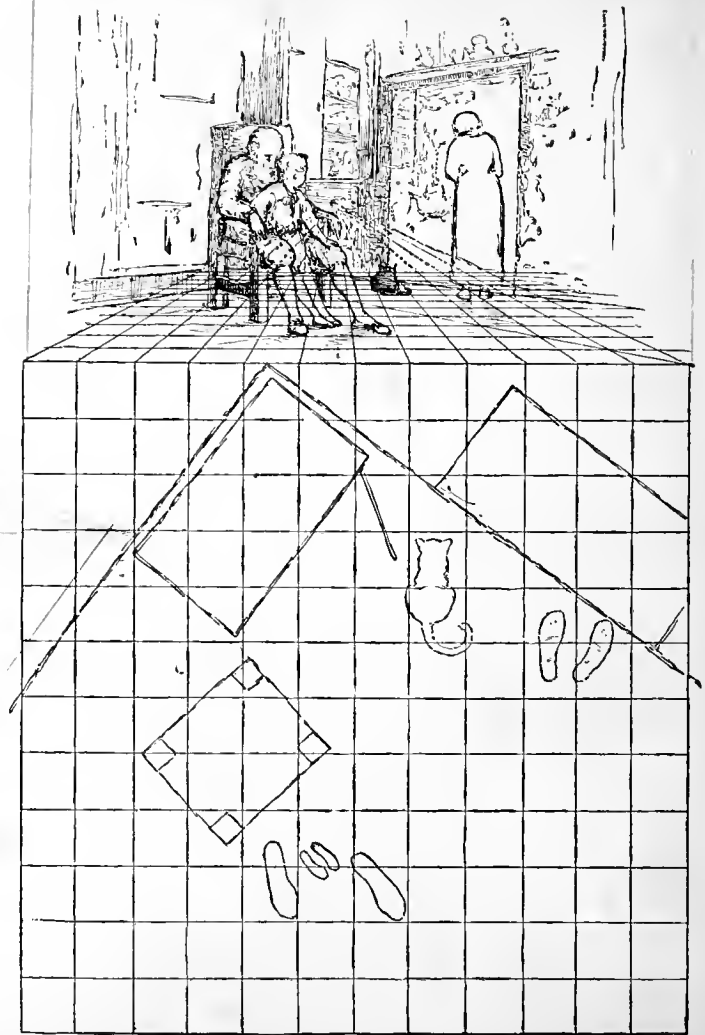

Fig. 89.

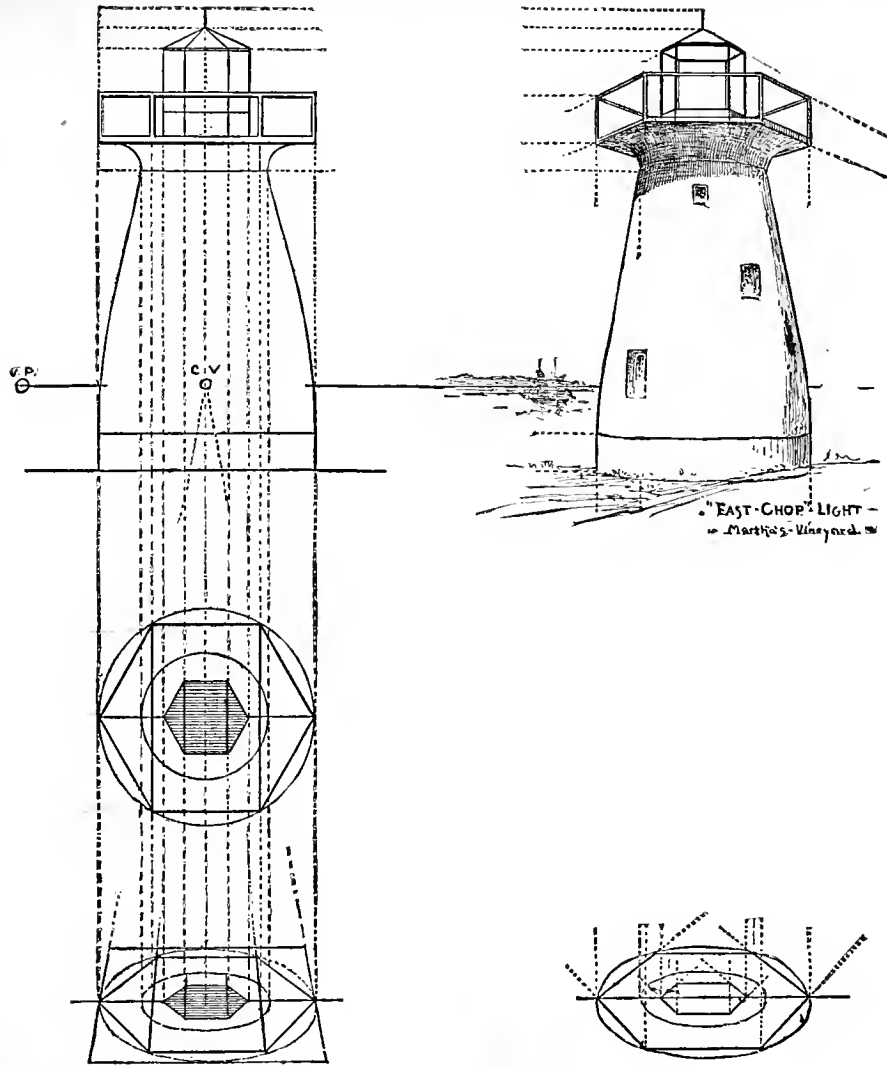

Fig. 87.

This method of the perspective plan is a very good one when you have polygonal or circular structures to draw, like that in Fig. 87, let us say. By setting your geometrical elevation side by side with the perspective view, you can carry the heights across from one to the other with a rule or "T" square. This will give all the heights on some one vertical plane, and you can then transfer them backward or forward in the picture in the way that has already been explained. In Fig. 87 the lines of the hexagons are lengthened a little, as if their vanishing-points had been used, (and so they were in this case,) for the reason that it was just as easy to draw hexagons in this position as it would have been to draw squares, but the whole drawing could have been made with one vanishing-point just

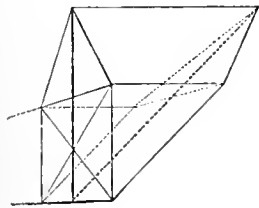

Fig. 85.

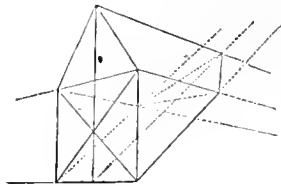

Fig. 86.

as well.

Fig. 88 shows the same method applied to another kind of building. If either of these seem at all hard to understand, however, I beg the reader not to trouble himself

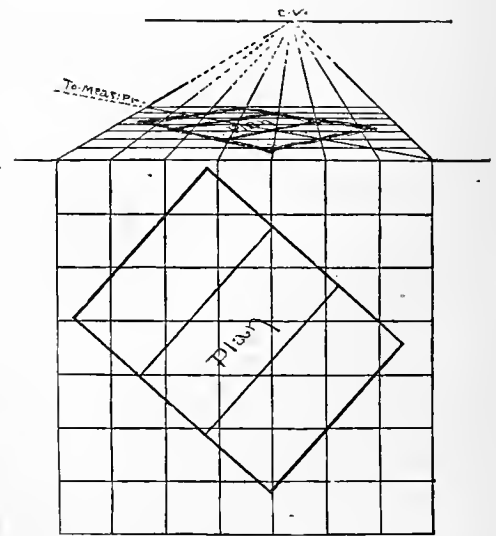

Fig. 90.

about them, as anything of this kind can be done just as accurately by means of an application of parallel perspective which is presently to be explained, and which is the one usually made use of by artists where a good many objects have to be located and their sizes indicated.

By looking at Fig. 89, you will see that almost any problem that is likely to arise in an artist's practice can be solved by means of one-point perspective. You have only to make a geometrical plan of your subject, cover it with squares as big or as little as you choose, and, having put these squares into perspective, as is shown in Fig. 45 (page 38), proceed to sketch your plan on the perspective squares by exactly the

same process as that which one is accustomed to employ in enlarging or reducing a picture by means of geometrical squares.

Fig. 90 shows the plan used in Figs. 79, 80, and 81 drawn in this way, and Fig. 91 shows a row of arches treated in the same manner.

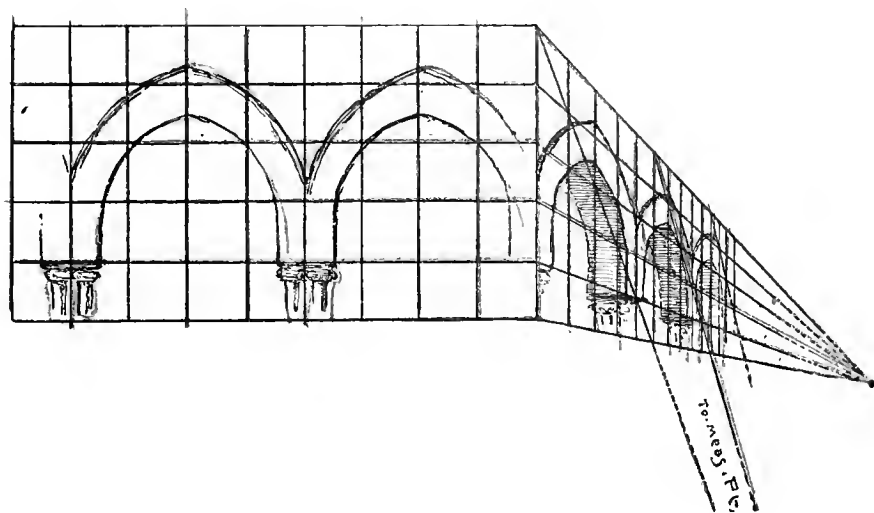

Fig. 91.

CHAPTER VIII.

SHADOWS.

IF our thoughts have so far been occupied with the outlines of objects rather than with such elements of pictorial effect as are furnished by shadows and reflections, it is not because less importance is attached to the latter, but simply because it is not possible to think about everything at once. And as the subject must be divided somewhere, it has been thought best to limit our inquiries, at first, to those things which are most obviously elementary, and to take up afterward those which great numbers of drawings have to do without altogether.

As a matter of fact, the shadow is usually of more importance, from a pictorial point of view, than the outline, and I cannot help thinking that it is a great mistake to separate the two in practice, as it is common to do in drawing-schools.

From the very first, pupils should be taught to see that it is the shadow that shows the form, and that it is only by drawing this that the character of the object is expressed.

Drawings made in outline are diagrams, not pictures, and no one can be said to know how to draw unless he grasps the laws which govern the representation of shadows as well as those which stand for the shapes of things.

The study of the light and shade *on* objects hardly comes within the province of our present investigation, but the perspective of the shadows which they cast forms, not only one of the most interesting and instructive branches of our subject, but it is also one of the easiest to understand and apply, as the same rays of light which cast them measure them also, and the vexations of separate measuring-points are all avoided.

It is hoped that the illustrations to this chapter will, for the most part, explain themselves, and so render unnecessary any other explanation than that which a kind of running commentary on them will be found to furnish.

The direction and length of the shadows of the posts in Fig. 92 vary, of course, with the time of day; but one of them being drawn, the others are easily made to conform to it. The oblique lines through the tops of the posts are rays of sunlight which, being parallel too, have their own vanishing-point, which

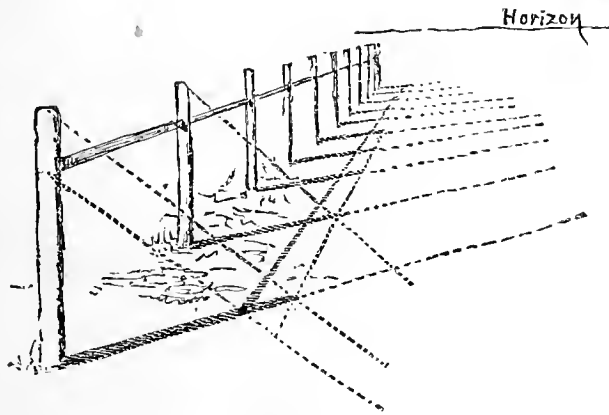

Fig. 92.

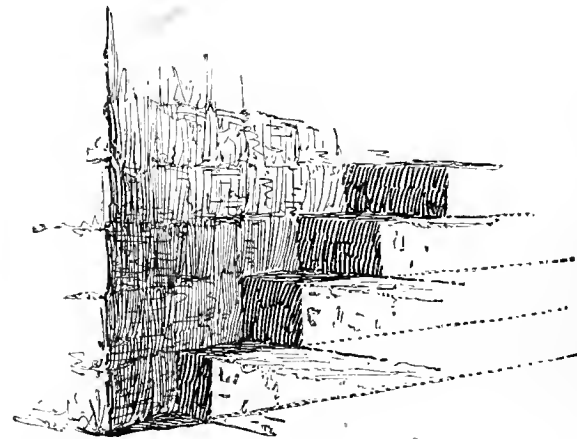

Fig. 93.

is quite independent of any other that would be employed in the picture. These lines would measure the shadows of the posts if they were not all measured at once by a line through the ends of them parallel to the rail. Notice this shadow of the rail, and remember the lesson which it has to teach; namely, that:

The shadow of a line on a surface to which it is parallel is always parallel to the line itself.

Notice, also, that what is true of the horizontal line in this illustration is just as true of the vertical

one in Fig. 93. Notice, also, in both of these, as well as in the one which follows, Fig. 94, how well the character of the surface on which the shadow falls is expressed by the shadow, and do not forget that all the outlines you can ever draw will not convey half as good an impression of a surface as a single shadow falling across it.

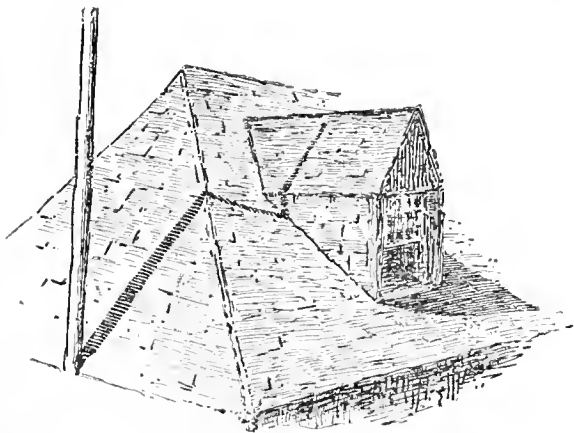

Fig. 94.

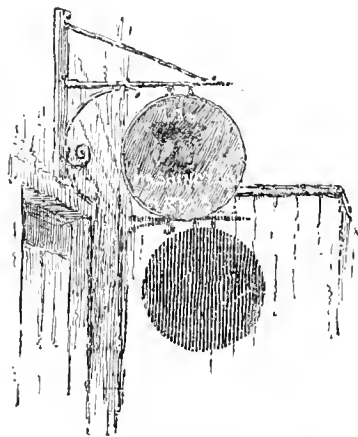

Fig. 95.

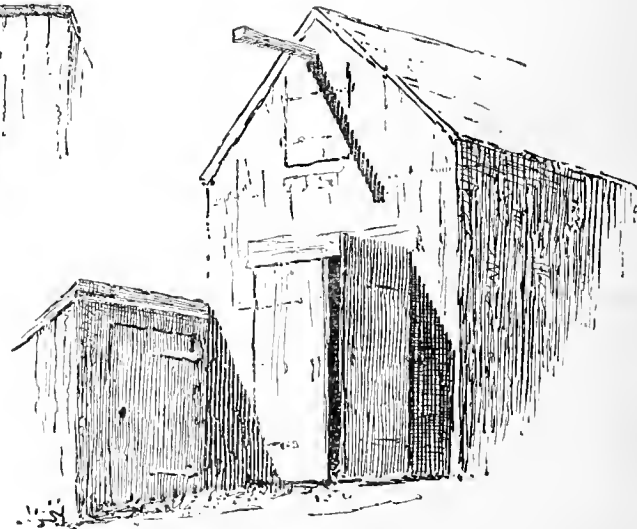

Fig. 96.

What was just noted about lines is manifestly just as true of shapes, and our first rule may readily be made to read as follows :

The shadow of any plane figure on a surface to which it is parallel is a similar figure.

Where the shadow is cast by sunlight, it is not only similar to the line or shape which casts it, but it is of just the same size. When it is cast by artificial light, however, the shadow grows larger as the surface on which it falls is farther removed.

The shadow of a line on a surface with which it is at right angles changes with the direction of the rays of light, and so furnishes a pretty accurate indication of the position of the sun. You can see this very nicely in Fig. 92 and in Fig. 96.

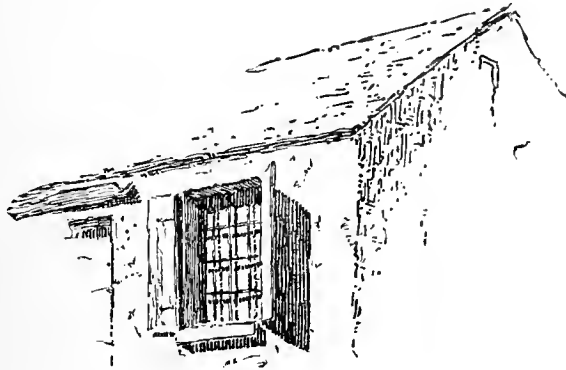

Fig. 97.

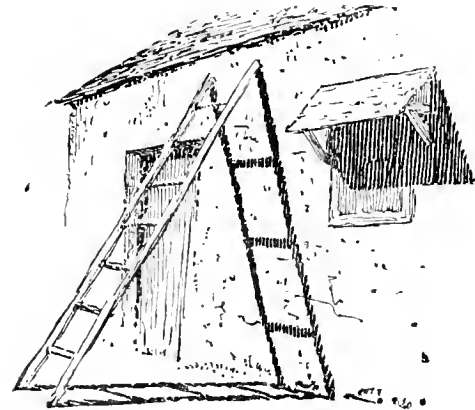

Fig. 98.

Fig. 97 shows the shadows of lines on surfaces to which they are parallel, on those with which they are at right angles, and on those to which they are oblique.

Test the width of the shadow on the wall by drawing rays of light through the corners of the shutter, and, having found their vanishing-point, see if the shadow on the curtain inside the window is of the right width.

Fig. 98 shows the shadows of oblique lines on two surfaces at once. Go over it, drawing with a ruler lines which represent the rays of light, and see if the shadows of the rounds of the ladder agree with that of the little roof over the window.

Go over Fig. 99 in the same way, and see if you can find out how the position of the shadow of each object and angle was determined; for they were all determined by means of a ruler.

The shadows of a few points can be found easily enough in Fig. 100 by applying the results of our observations on the preceding illustrations, and the shadow sketched accurately enough through these.

Of course, you will enclose the circle in a square, as has been done with the horizontal circle beside

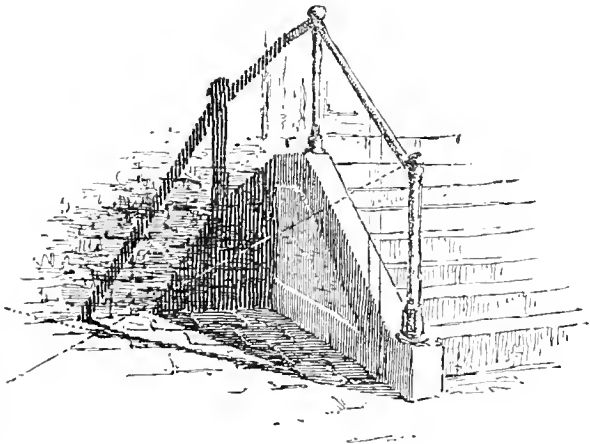

Fig. 99.

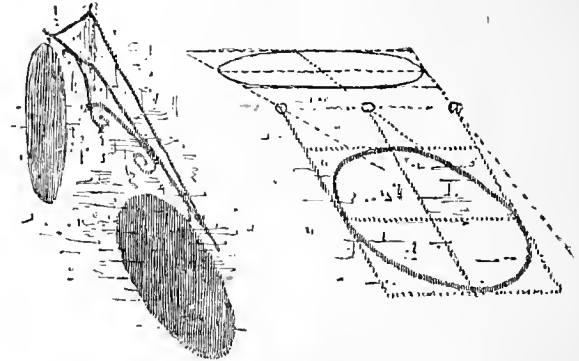

Fig. 100.

it, and draw an ellipse that will fit into the shadow of the square, and so make the shadow of the circle very accurate; but it is hardly necessary to fix more than two or three points in the shadow.

You ought, however, to be able to draw the shadow of a horizontal circle and of a vertical one as they appear on the wall in this illustration. These were drawn with the rays of light falling at the same angle for both, but you see they are very much alike, notwithstanding the difference in the position of the circles. One shadow is a little narrower and "steeper" than the other; and that is about all the difference to be seen between them. If you remember about how they look, you can sketch any such application of

either of them as is shown in Fig. 101 readily and confidently enough. As shadows always become the most conspicuous part of the plane on which they fall, it does not need to be pointed out that their van-

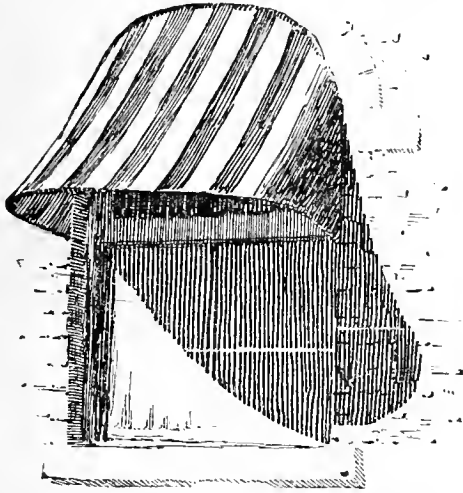

Fig. 101.

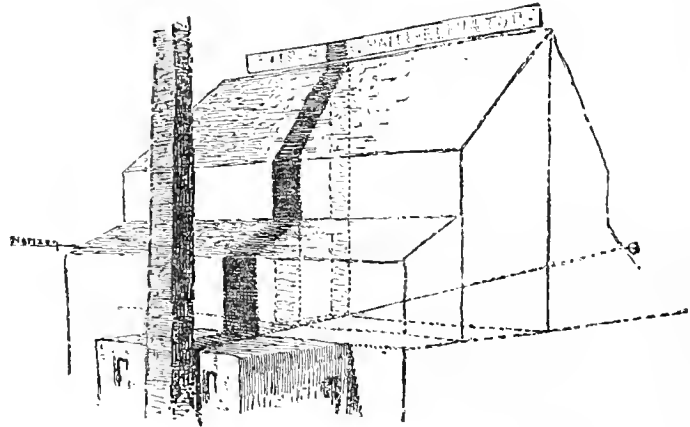

Fig. 102.

ishing-points are always to be found in the horizon of that plane. Fig. 102 shows how a shadow may be

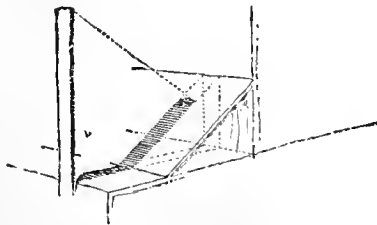

Fig. 103.

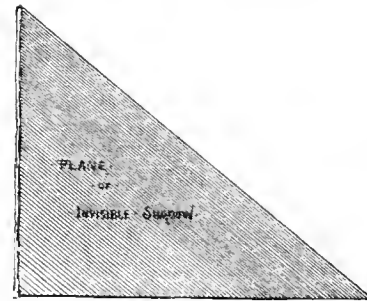

Fig. 104.

“tracked” from one plane to another by means of the surface on which it is easiest to find its vanishing-

point, even if this surface has to be partly an imaginary one. Fig. 103 shows how such a shadow is followed when the object casting it has to be lengthened in imagination in order to enable us to determine its direction.

If we looked into the matter a little more deeply—and it is necessary to do so in order to understand any but the most elementary facts of appearance—we should find that every line casts in space a plane of invisible

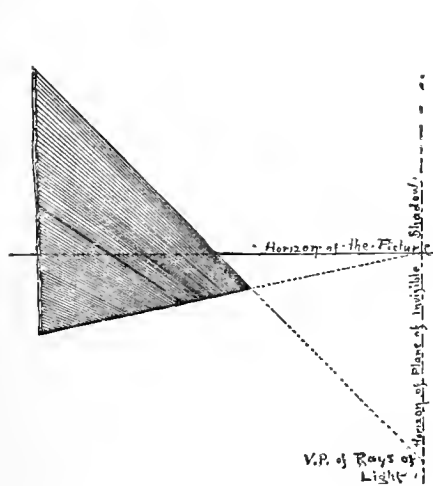

Fig. 105.

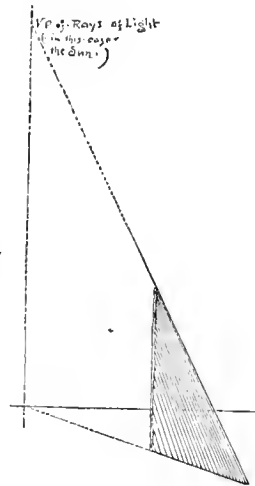

Fig. 106.

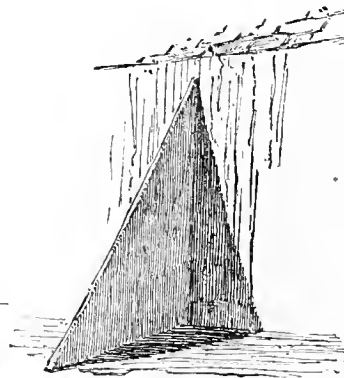

Fig. 107.

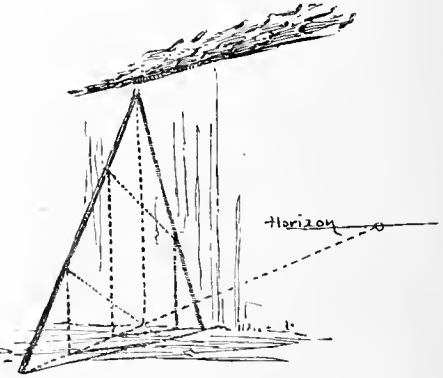

Fig. 108.

shadow, as it is called, though it becomes visible on the dust or mist that sometimes fills the room or the street; and it is the intersection of this plane of shadow with some other surface that forms the visible shadow. This plane of invisible shadow is, then, to be treated just like any opaque flat surface; it may have its own horizon and as many vanishing-points in it as may be called for. Fig. 104 shows such a plane when it is parallel with the plane of the picture, so that the edge where it cuts the ground is parallel with the horizon and has, consequently, no vanishing-point. In Fig. 105 this line has a vanishing-point. Notice that the

shadow on the ground, which, of course, lies in both these planes, has its vanishing-point in both their horizons, just as we saw must be the case with the edges of the roofs in Fig. 20 (page 17).

This illustration (Fig. 105) shows the shadow as it looks when the light comes from behind the observer, but it may just as well come from somewhere in front of him, and then the case will be as shown in Fig. 106.

It is by understanding this matter of the planes of shadow that one is able to determine readily the

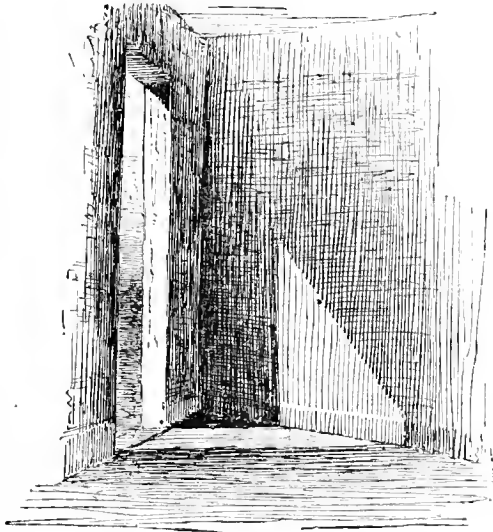

Fig. 109.

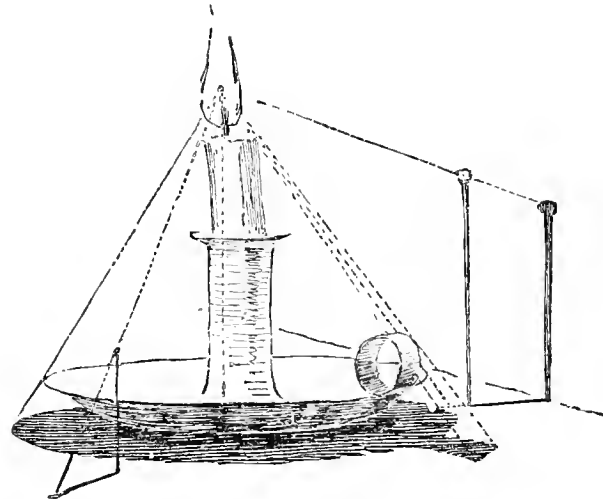

Fig. 110.

shadow of any point in an oblique line, like the side of the ladder, for example, in Fig. 98; or the slight buttress or partition in Fig. 107. The method of fixing the shadows of separate points is shown in Fig. 108.

The dotted verticals belong to the plane in which the oblique line is situated, while those on the ground and wall are the lines where the planes of invisible shadow would cut the ground or the wall. The oblique lines in the air by which these last are cut off in the right place are rays of light.

Fig. 109 shows the effect obtained when the most important factor in the effect is a mass of light bounded by shadows, instead of the reverse. Go over it, and make sure that there is no mystery about it.

Where there is an artificial light to deal with, instead of the sun or moon, the rays radiate instead of being parallel to each other, that is all; no two planes of invisible shadow can, then, ever be parallel if cast by artificial light.

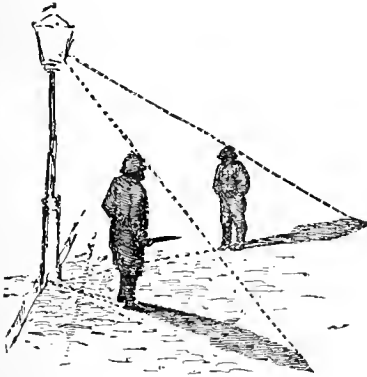

Fig. 111.

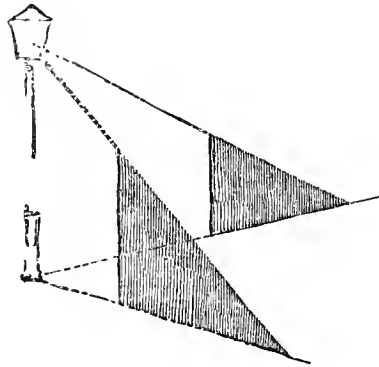

Fig. 112.

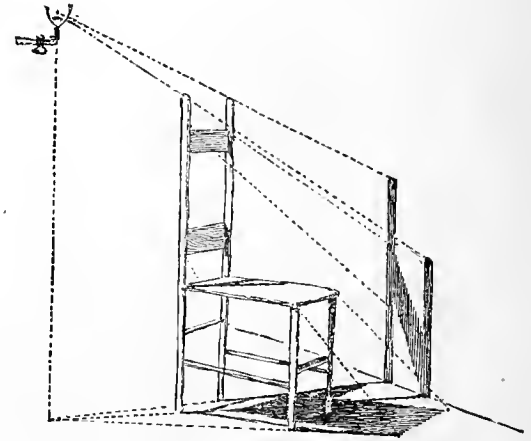

Fig. 113.

The candle in Fig. 110 illustrates this pretty well, and Fig. 111 better still, perhaps; while the bare facts to be noted in the latter are stated diagrammatically in Fig. 112.

Fig. 113 is simply a little more complex application of the same principles. It will explain itself to anyone who cares enough about the subject to study it with a little care.

CHAPTER IX.

REFLECTIONS.

THE laws governing reflections are very few and very simple, but for want of understanding them, such as they are, the beginner often gives himself a good deal of trouble about them.

It is only necessary to remember that any point in an object which appears in reflection seems to be just as far beyond or below the reflecting surface as the point itself is on this side of or above it.

This is really the whole statement of the matter, and any question that may ever arise concerning the perspective of reflections might be settled by the application of this rule alone.

As the establishing of any great number of points might become a somewhat tedious process, however, even if carried on in imagination only, other rules may be deduced from this one, or rather the truth which this one expresses may be put in other forms whose application to pictures may seem to be more direct.

A moment's thinking will enable anyone to put it into this form, for instance: The reflections of lines which are either parallel with the reflecting surface or at right angles to it have just the same vanishing-points as the lines themselves, and if they have the same vanishing-points, of course they have the same measuring-points, and the reflection has no other influence on the lines than simply to extend or to double them (see Figs. 114 and 115); and as far as lines alone are concerned this is perhaps enough to say about them, for in the case of those which are oblique to the reflecting surface one point can be established in the reflection of each, by the method illustrated in Fig. 74, page 62, and the proper vanishing-point found by extending the line to its horizon, as is done with any other line. Even this is not necessary

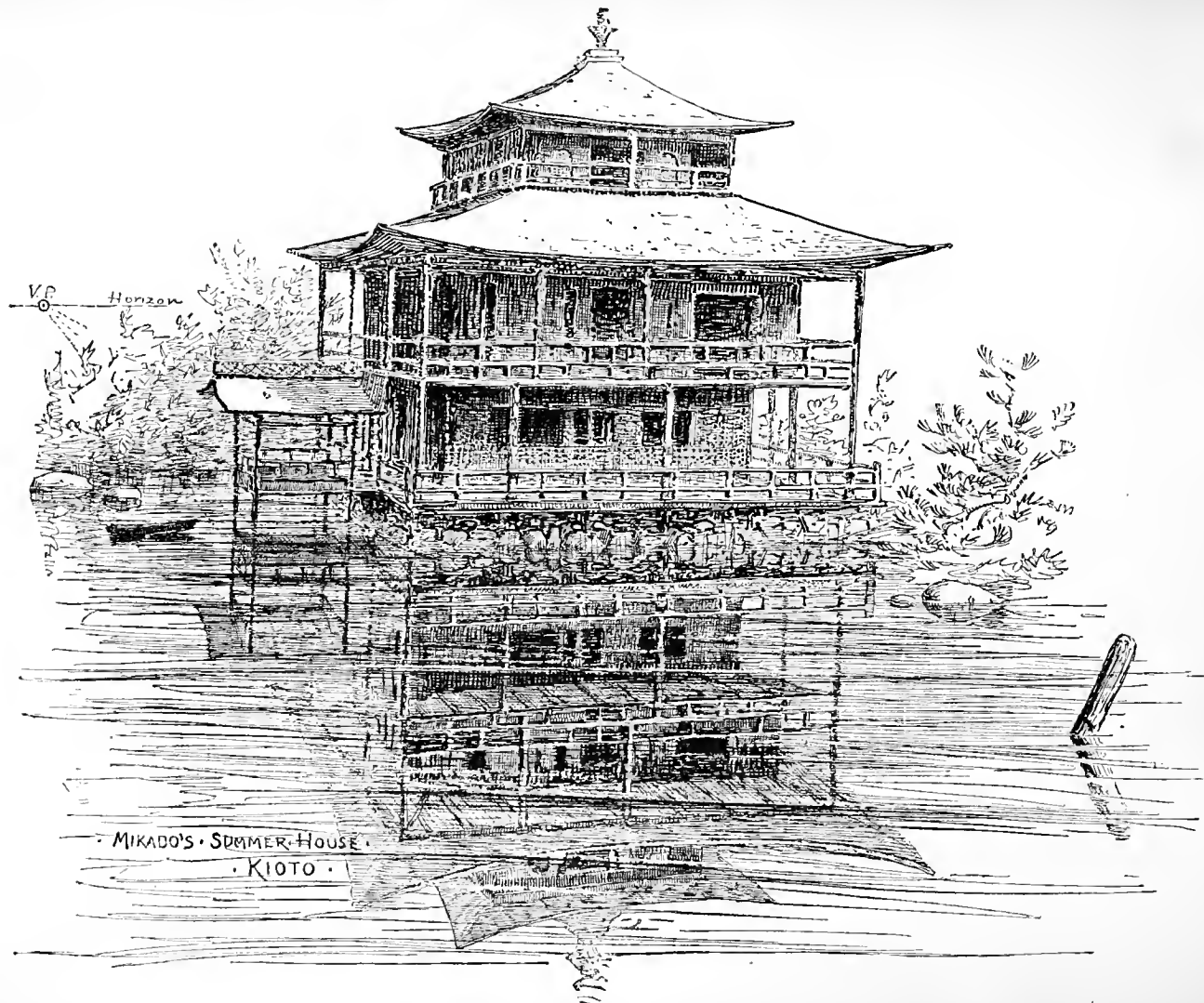

Fig. 114.

unless one has to draw several such lines which are parallel, for the location of the end of the reflection is all that is needed (see Fig. 116). If this is the whole truth about the reflections of points and lines, is there anything else that requires explanation? There can hardly be anything, unless it be the fact that surfaces which are visible in the object are often wanting in the reflection, and *vice versa*, either because the surface which is reflected is the reverse of that which is in sight on the object, or because one of them is



Fig. 115.

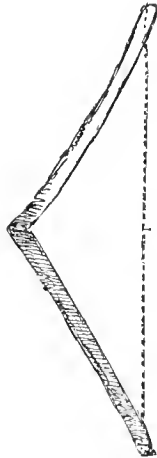

Fig. 116.

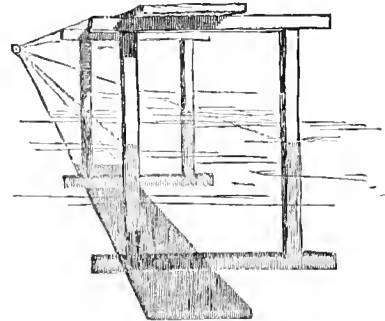

Fig. 117.

concealed by some intervening object. If, then, we were to examine these last statements a little in detail, we should probably exhaust the subject.

Fig. 114 illustrates the first one well enough, and of those that follow it all except Figs. 115, 116, and 117 illustrate both.

Fig. 116 shows that the modifications in the appearance of the object reflected which are produced by the first of these influences may be considerable. (The drawing does not quite agree with the state-

ment, because the top of the board is not in sight, but anybody can see that it might just as well have been, and the indulgent reader will excuse the discrepancy.)

For what we see in the reflection is obviously what we should see in the reality if the eye were just as far on the other side of the mirror as it happens to be on this. This is expressed diagrammatically in Fig. 118.

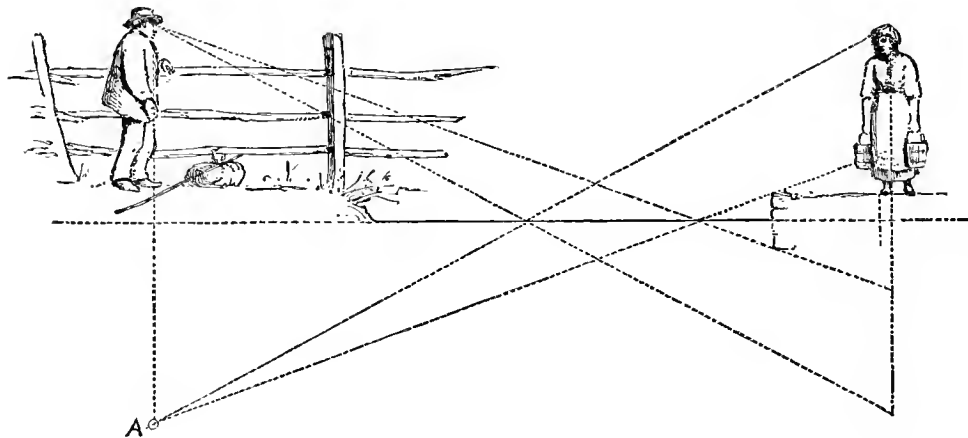

Fig. 118.

What the wayfarer who is here represented sees in the water is just what he would see out of it if his eye were as far below the surface (at A) as it actually is above it.

Fig. 119 shows exactly what this amounts to, and Fig. 120 emphasizes both the statements which the diagram has been made to illustrate, for by showing what would be seen in reflection if the bit of intervening wall were removed it makes more apparent the difference in the appearance of the object which is caused by reversing it.

If the reader will turn the page bottom upward he will see that the figure seems, in the reflection,

to be walking along the edge of a wall which is just as far above the eye as the edge of the real wall is below it, *plus twice the height of the wall above the water.*

Fig. 121 shows how the size of the portion of an object which will appear in reflection may be accurately determined. The dotted line through the bottom of the post on the right may be any line on the



Fig. 119.

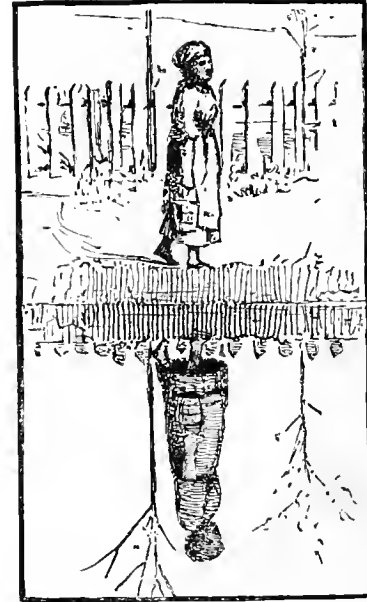

Fig. 120.

surface of the ground. *Any* line, remember. It may run in any direction you like. Having continued this line to the horizon, and so found its vanishing-point, it is easy to draw another one parallel with it and directly under it on the surface of the water, as if the water were extended indefinitely, and the post standing in the water; then the case of the post is precisely like that in Fig. 115.

If the bank, as originally drawn, conceals the reflection, that is the end of it. If part of it is to appear you will know just how large it ought to be.

The dotted lines connecting the parallels in Fig. 121 are only to show the shape of the bank as it is

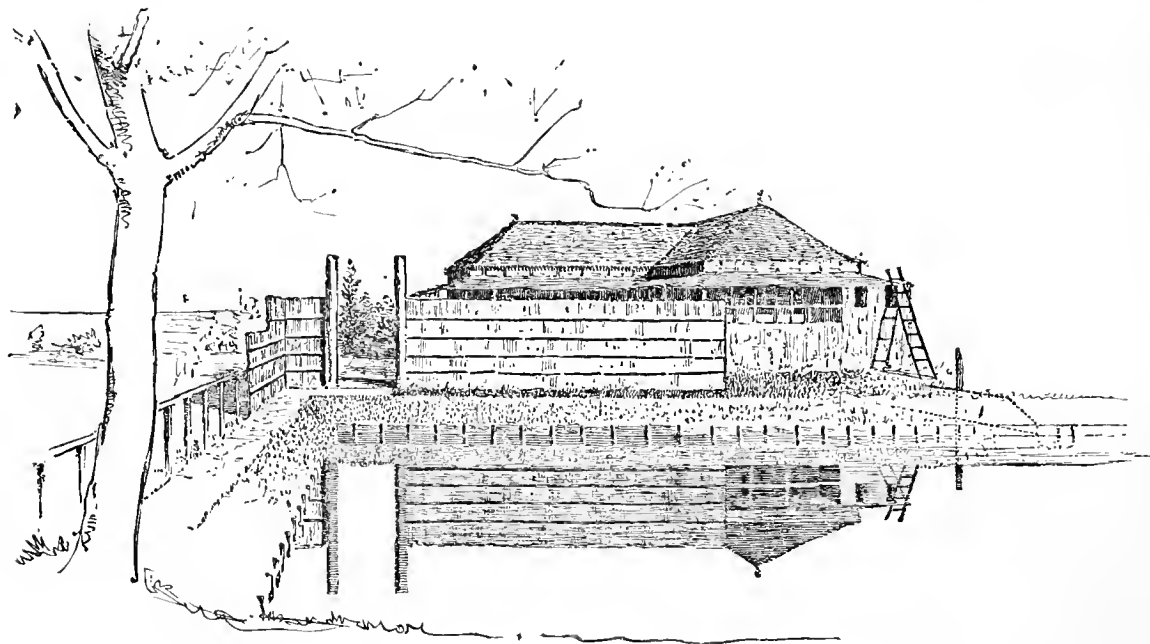

Fig. 121.

described by the line on the ground as it runs down to the water. You can determine the slope of the oblique one with mathematical exactness if you care to study the drawing a little; but do not trouble yourself to do so unless you are really interested in the process. Anybody can sketch the line quite accurately enough for all practical purposes if he has any imagination at all.

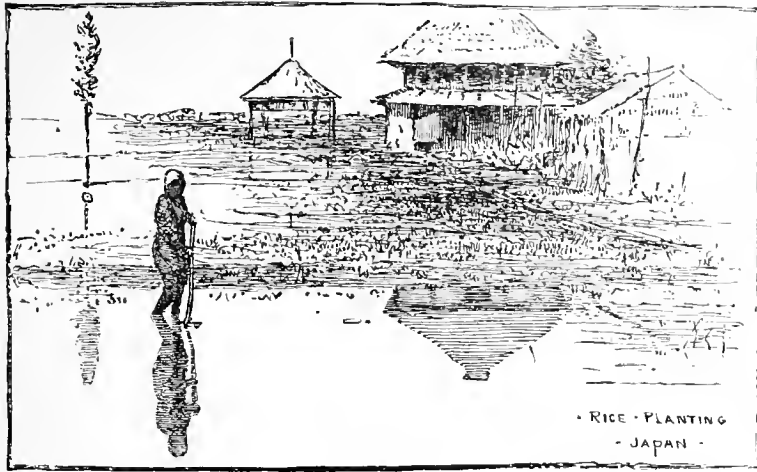

Fig. 122.

It will be seen that any vanishing-points or measuring-points which may have been used for the lines and forms in front of the glass have been used in just the same way for their reflections, and one figure is measured by means of the other, just as if there were in reality two figures. In the case of perfectly regular and symmetrical plane figures like the slabs in the floor, even the reversal of them in the reflection is not apparent, and one part of the picture is merely a continuation of the other.

In Fig. 122 the same rules are applied to objects standing by themselves as much as the post in Fig. 115, one of them entirely reflected, the reflections of two others cut off by the line of the bank, and that of another one not appearing at all. The laws governing reflections are, if possible, more obvious in the case of vertical mirrors than in those which are horizontal (see Fig. 123).

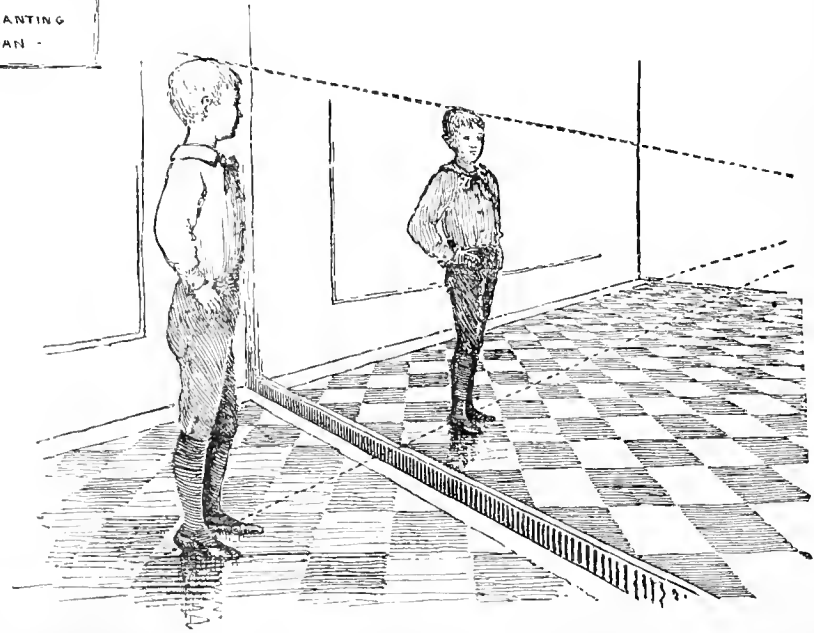

Fig. 123.

CHAPTER X.

CYLINDRICAL OR CURVILINEAR PERSPECTIVE.

IN all the examples which have hitherto been given the picture has been regarded as a vertical plane, so that all vertical lines appear vertical in the picture. When, however, you draw things as they appear when you are looking up at any considerable elevation, or downward at objects at any great depth below the eye, you notice the convergence in parallel vertical lines just as much as in any others, and may, perhaps, feel inclined to represent them so. In that case you are simply regarding your picture-plane as tilted one way or the other, so that vertical lines, being no longer parallel with it, they, too, have a vanishing-point which you locate just as you have learned to do with others; that is, by sketching any two of a set, and carrying them out until they meet, taking care that the rest of the picture is made to agree with this part.

This condition exists as a possibility, but probably no one ever had occasion to work out a drawing in this way except as a curiosity, and so it can hardly be necessary to go into details of the process here.

But the case of very long horizontal lines, which seem in nature to have vanishing-points at both ends, is of somewhat more importance, as its recognition frequently modifies very appreciably an artist's treatment of his picture.

Figs. 124 and 125 will make this clearer than any amount of explanation in words could do.

The actual relations existing between the objects represented are shown in Fig. 124; that is, the three houses are all in a row. The lines of one have precisely the same directions as those of each of the others, and the fronts of all three are parallel with the fence.

But the eye is the most restless of organs, and undoubtedly we should *see* something a good deal like

what is shown in Fig. 125 if we occupied the position which the photographer did when he took the view from which that drawing has been made.

Something like it, but with this difference: our eyes would be *continually* moving, so that the long lines would appear curved, whereas the camera was allowed to remain in one position until one impression was

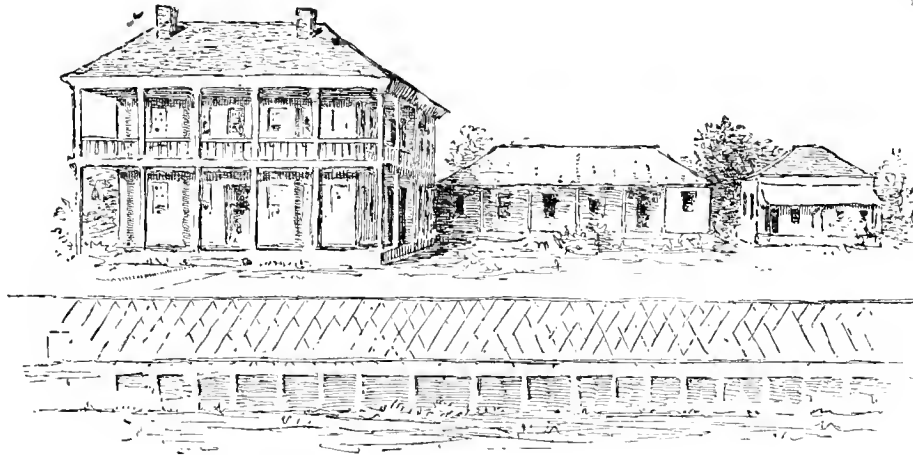

Fig. 124.

recorded, and then turned in another direction, to remain fixed a little while longer—the result of which is a series of separate and distinct impressions regarding the objects before us.

Now, there can be no doubt about the truth of this last picture, when the conditions under which it was made are understood.

As has just been said, it was drawn from a photograph, and it undoubtedly records just what the observer, who happened also to be a photographer, actually saw.

No greater changes were made in the position of the camera in taking the picture than the observer's head underwent in looking at the view.

But looking at views is not making pictures, and the question arises as to which is the true picture of

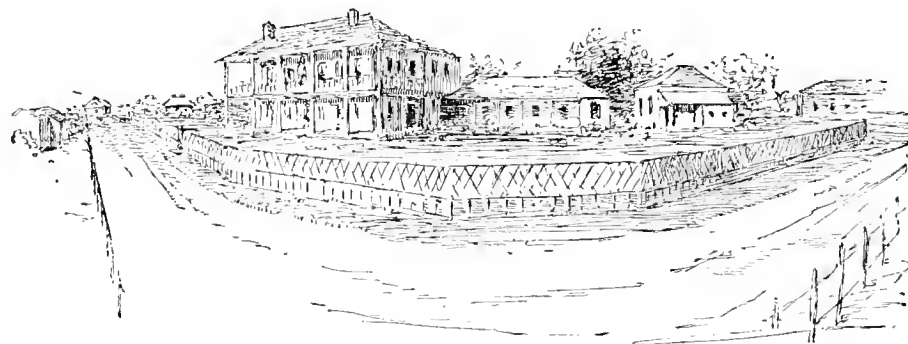

Fig. 125.

the place after all. By which is meant: Which picture produces on the observer's mind the impression most like that which the place itself would produce?

The impressions recorded in Fig. 125 form, not one picture, but a series of pictures, made on the inside of a polygonal prism, the surface of which is "developed," or reduced, to a flat surface afterward. If the impressions were continued without interruption, the record of them would have to be made on the inside of a cylinder which, being unrolled, would give curves where Fig. 125 shows jointed straight lines.

The conditions under which the objects represented would in that case be studied, and a comparison of the same with those under which perspective drawings are usually made, are indicated in the diagrams which follow.

Fig. 126 shows the relation existing between a row of arches with square piers, the eye of an observer,

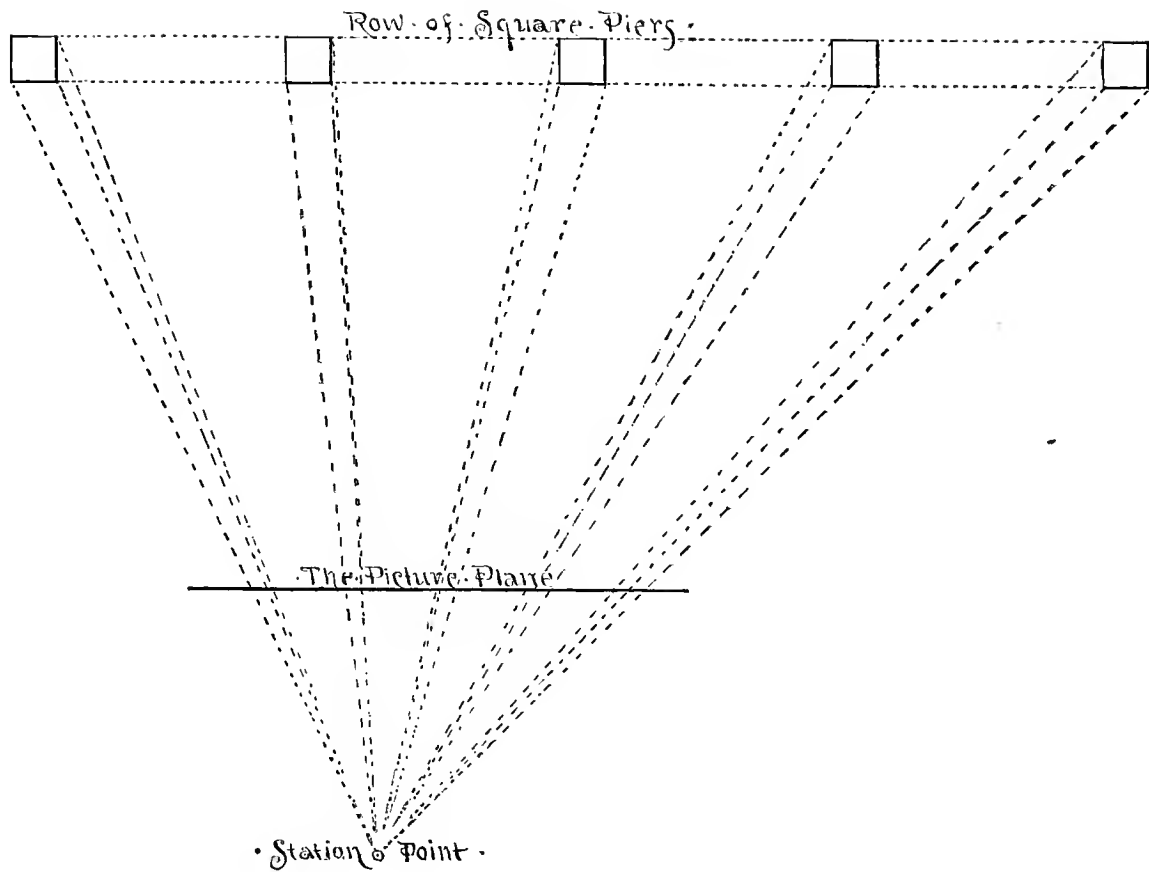

Fig. 126.

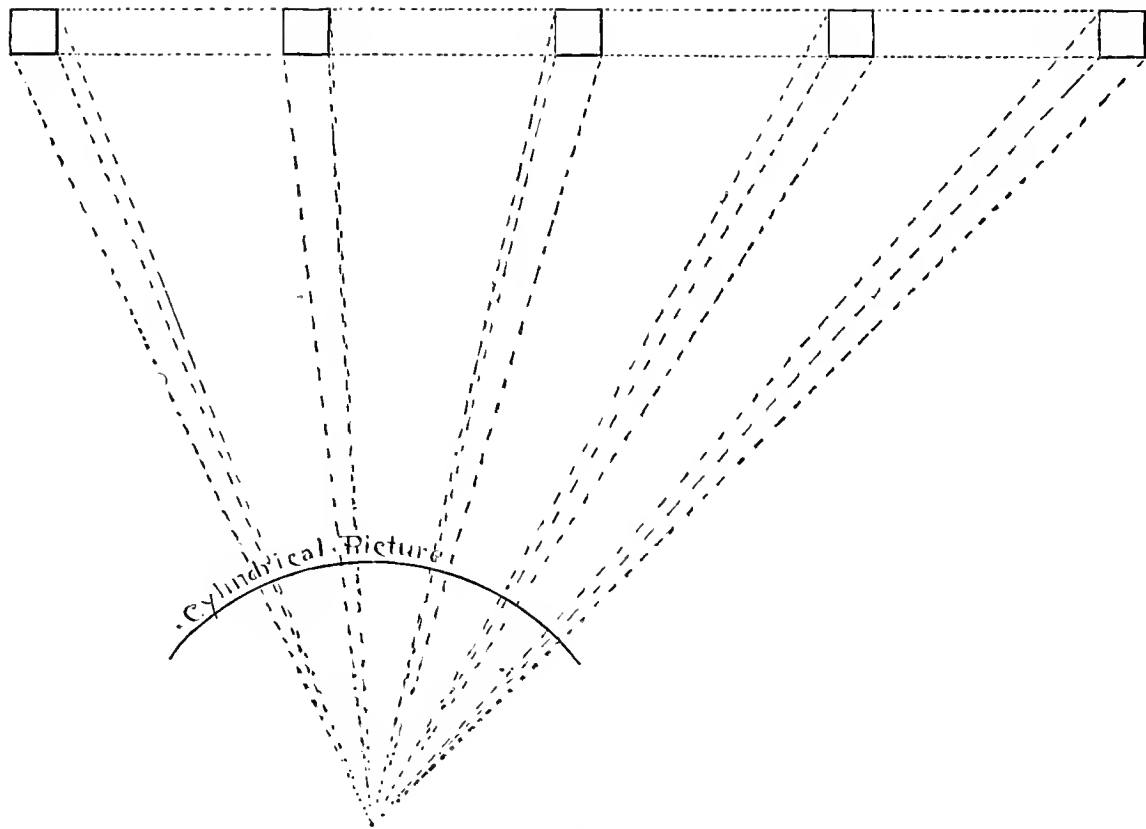

Fig. 127.

and a picture-plane fixed as was the window-screen described and illustrated in the first chapter. The dotted lines running from the piers to the station-point show just how wide each pier would have to be in the picture; and, of course, the reader does not need to be told that the piers would all be drawn of the same height, so that the effect would be something like that in Fig. 130.

Now, suppose we were to substitute for the picture-plane employed in Fig. 126 the curved surface which is shown in Fig. 127. The conditions would then be materially changed. But this is precisely the state of things which the revolving camera represents, and which your picture-plane would represent if you kept turning it so as to have it directly in front of you whichever way you were facing.

You will see by the diagram that, as represented in this cylindrical picture, the thickness of the piers as they recede, instead of increasing as it does in Fig. 130, remains about the same as that of those nearest to the observer, notwithstanding the fact that the more distant piers are seen cornerwise while the nearest ones present hardly more than the width of one face to the observer. And you must also see, that *in a picture, every part of which was at the same distance from the observer's eye, the piers would appear shorter as the piers themselves were farther away.* So that, if the observer were to draw on the cylindrical screen shown in Fig. 127, and then flatten it out, the result would be like that in Fig. 128.

But pictures are not usually made on the inside of cylinders, to be unrolled afterward. If they are made on this kind of a surface, as "panoramas" or "cycloramas" are, they are intended to be seen in just that position, and big circular houses are built for their special accommodation—built, too, in such a way that the observer cannot get very far away from the station-point and must, perforce, see the picture under just the conditions which governed the perspective calculations on which the representation was based.

Fig. 128 shows that if we could unroll one of these cylindrical pictures we should find that the representations of all straight lines, except the vertical ones, were really drawn as curves, so that the panorama is said to be drawn in curvilinear perspective; but when seen as they are intended to be seen, they look straight, as they certainly would not do if they had been drawn straight on a flat surface which had been rolled into the form of a cylinder afterward.

Now, on the face of it, the attempt to make flat pictures as if they were cylinders unrolled seems just as absurd as it would be to try to make cylindrical pictures out of flat ones rolled up.* There is more to the question than this, however, as we shall see.

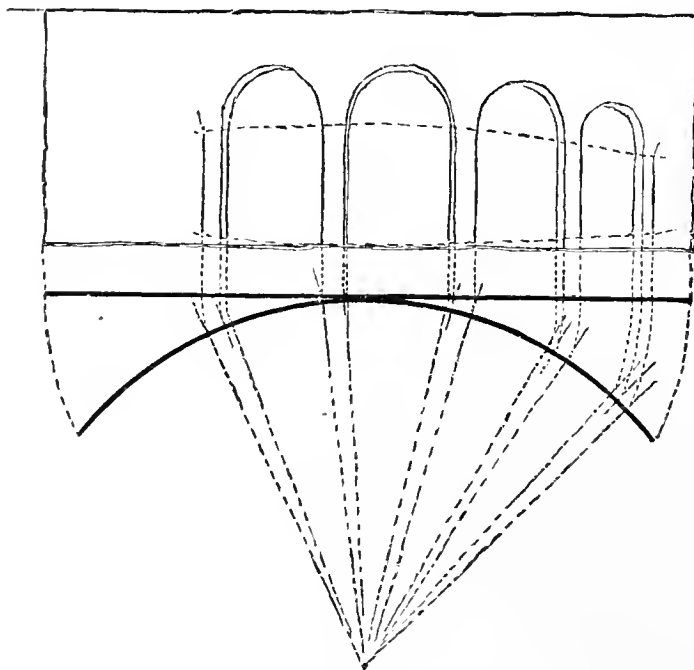

Fig. 128.

Any picture—no matter whether it is drawn on a flat surface or on the inside of a cylinder—can appear quite right only when the observer's eye—and *one* eye, at that, remember—is at the station-point.

*The reader who cares to investigate the mathematics of curvilinear perspective as applied to the construction of cycloramas will find the subject explained and illustrated with admirable fulness in Professor Ware's *Modern Perspective*.

If you have a cyclorama to exhibit, you can build a little enclosure for the spectator just where he should be, in the middle of the building, and keep him there; and in exhibiting single pictures of considerable importance very much the same thing is often done, but in the vast majority of cases the artist cannot count upon anything of the kind. If he could, it would be a very much simpler matter to make pictures than it is.

Remember, however, that, if drawn according to the principles of perspective which have been considered in the preceding chapters and under conditions which your window-screen illustrates, the picture will always be correct as long as it is seen from the station-point. The eye placed there may wander over the picture as restlessly as it does over the natural scene, and everything represented falls into its place in the one case just as it does in the other; the long lines in Fig. 124 foreshorten themselves, and the road and the fence in the foreground taper away to the right and left in the picture just as they do in nature. In fact, the picture cannot help being deceptively right (so far as its drawing is concerned) as long as the eye is where the draughtsman counted on having it when he made the picture.

Even the question about a good part of the picture being out of focus, which has often been discussed, is one which takes care of itself entirely. One part of the picture is just as much out of focus when the eye is occupied somewhere else as the corresponding part of the natural scene would be. There is not a particle of difference between the two cases.

The draughtsman has to think of something else besides getting his picture in true perspective, because he knows it will be looked at from every other point of view as well as from the one intended. Indeed, the chances are, that not one person in a thousand who ever sees it will get himself into the exact position for which its perspective is calculated. A few inches backward or forward, even, will change the whole effect, as everybody knows who has tried to draw on the window-screen.

Most of us have probably criticised often enough the perspective of the scenery at the theatre, not remembering, or not knowing, that it would have been a perfectly easy matter for the painter to make the effect deceptively right for some one-eyed man at the back of the house—in the gallery, perhaps—at the expense of

everybody else in the audience, to each of whom the effect would have been simply ridiculous. He cannot do this, and so he introduces a good many modifications which he knows perfectly well to be errors or liberties, for the sake of distributing these inevitable distortions more equitably. In making small pictures the draughtsman need not trouble himself much about this; but in large ones it becomes a question of very great moment, and the difficulty has to be solved by drawing all detached objects of any importance as if they formed separate pictures by themselves, which the artist introduces into and reconciles with his composition as a whole the best way he can.

All figures of men and of animals have to be treated in this way; and, indeed, nearly all objects not actually connected with other parts of the picture by straight lines may be, and usually are, drawn in this way, to the manifest advantage of the whole effect.

Fig. 129, which is traced from a photograph of Titian's "Presentation of the Virgin," illustrates this well enough. The buildings are drawn in "parallel" perspective, just as you would draw your neighbor's house across the way on your window-screen, but the drawing of the figures is a different matter altogether.

The following diagram, Figs. 130 and 131, shows the kind of effect which would have been obtained if the proportions of the figures had been determined by applying the principles of plane perspective. It simplifies matters to make use of one figure only, determining what its appearance would be in different parts of the picture, rather than to compare it with another figure; and, in order that we may determine with considerable precision what its appearance would be under different conditions, this simple architectural feature, an arcade, is introduced to measure its proportions by.

There is just such an arcade at the left-hand side of Titian's picture, as you see. I have supposed a case in which it should run straight across the whole canvas, the piers being about as thick as these people in the picture seem to be. Then, by changing the pillars into persons the monstrosity of figures drawn according to this principle is demonstrated.

The architecture does not look so very bad, even in the case of the pier that is farthest to the right; but whether it does or not there seems to be little help for it, and the master has, as you see, unhesitatingly drawn

his buildings in just this way. But suppose this same pillar transformed into a man, as at C (Fig. 131), the figure being in the picture about as he is at A, and you see at once that that would not do at all.

The result of trying to apply this kind of perspective to such pictures as this has sometimes led teachers to refer the drawing of the figures to the principles of cylindrical or curvilinear perspective. A little study of the diagrams, however, will show that this only helps us out of one difficulty to get us into another.

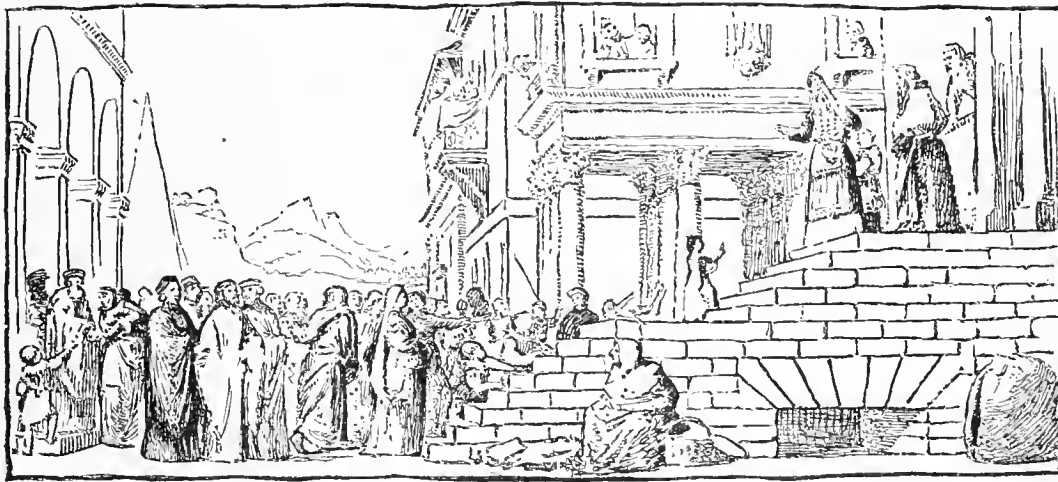

Fig. 129.

The arcade in Fig. 132 is drawn in cylindrical perspective, but the figures into which its piers are transformed (Fig. 133) are not much nearer the mark than those in Fig. 131. They do not broaden out as they recede, it is true, but they turn their backs on us (or their faces), as it was never intended that they should do; and, what is a far more serious matter, they grow smaller and smaller as they approach the frame, as they certainly do not in the original picture.

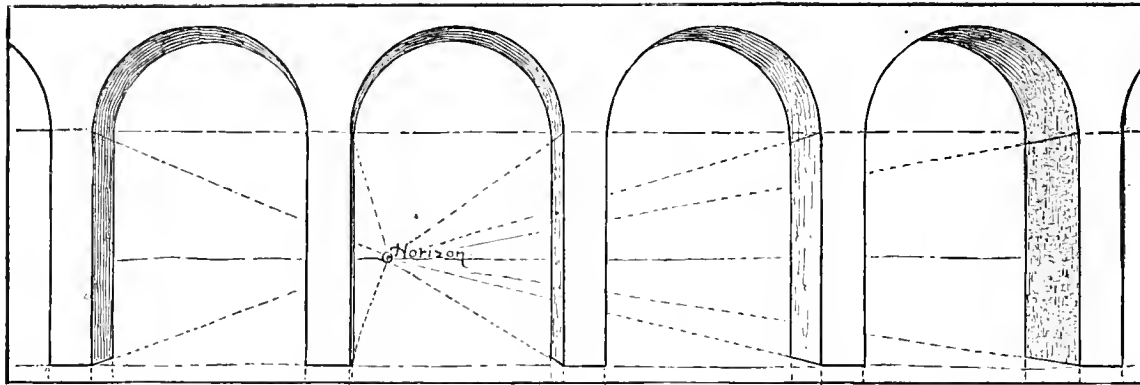

Fig. 130.

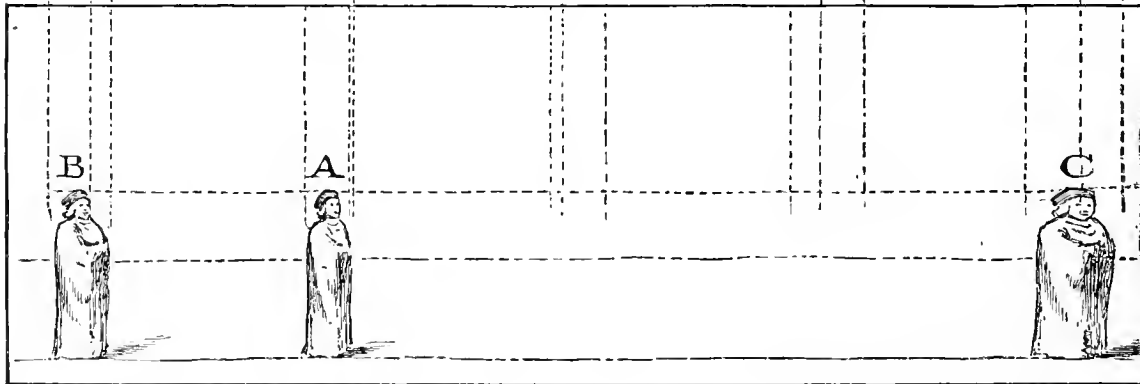

Fig. 131.

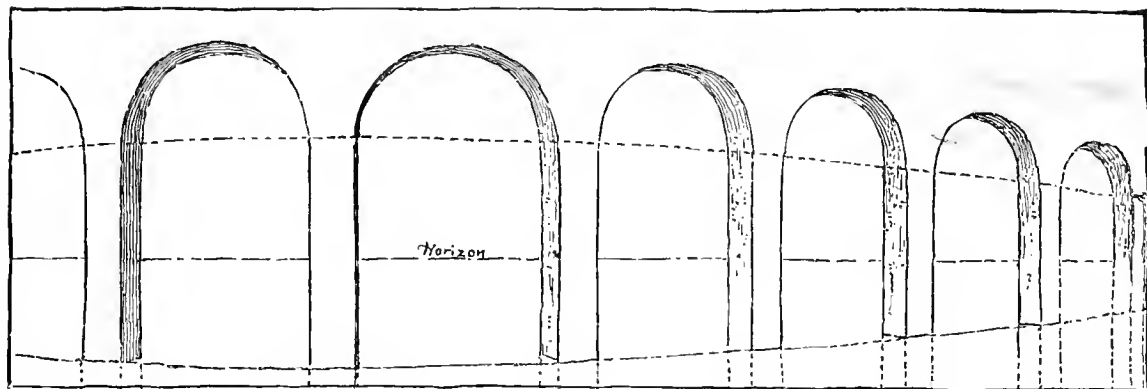

Fig. 132.

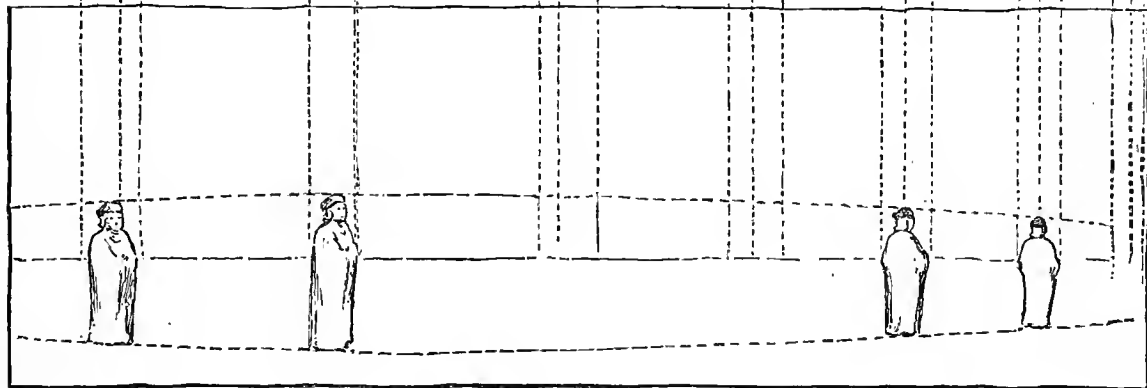

Fig. 133.

The fact of the matter is, then, that the figures in this picture of Titian's are not drawn in true perspective, either plane or cylindrical, as calculated for a fixed station-point. The buildings are, but the figures are not.

These last are drawn, not as they would look when the observer turned his head to look at them, turning his picture at the same time, but as they would look *when he moved along so as to be opposite to each in his turn.*

This construction, as applied to the arcade, is shown in Fig. 134, where just as many station-points have been used as there were arches to be drawn. It is introduced in this place only for the sake of its application to the human figure; but where simulated architecture, indefinitely extended, is employed, as it often is in decoration—on the ceiling of the Sistine Chapel, for example—the same practice has to be resorted to.

Pictures made in this way (and all large figure-pieces are so constructed) are records, then, of a succession of impressions obtained from a station-point which moves along horizontally before the picture and in a line that is parallel with it, as the visitor to a gallery moves along the rail which keeps him from going too near the pictures, and not from a station-point which revolves, as the visitor to the cyclorama has to do.

I have said that large pictures are always made in this way, but it would have been more correct to say that they are usually so constructed.

One is quite at liberty to draw his picture as if it were a cylinder unrolled if he chooses to do so, and that method has occasionally been adopted. It must be admitted, also, that the effect is admirable with certain kinds of subjects—extended landscapes, for instance, in which the principal forms are all at a considerable distance.

A good many of Turner's landscapes are drawn in this way, and there used to be a small picture of Allston's in the Boston Museum of Fine Arts to which the same method had been applied.

Both of these masters, moreover, applied the principles of curvilinear perspective to the straight lines of the architecture as well as to detached objects, which, of course, made the effect very much like that in Fig.

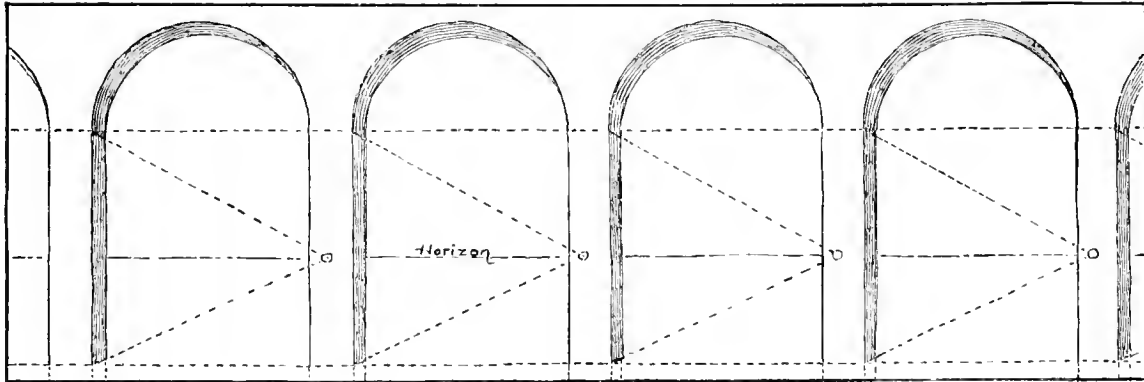

Fig. 134.

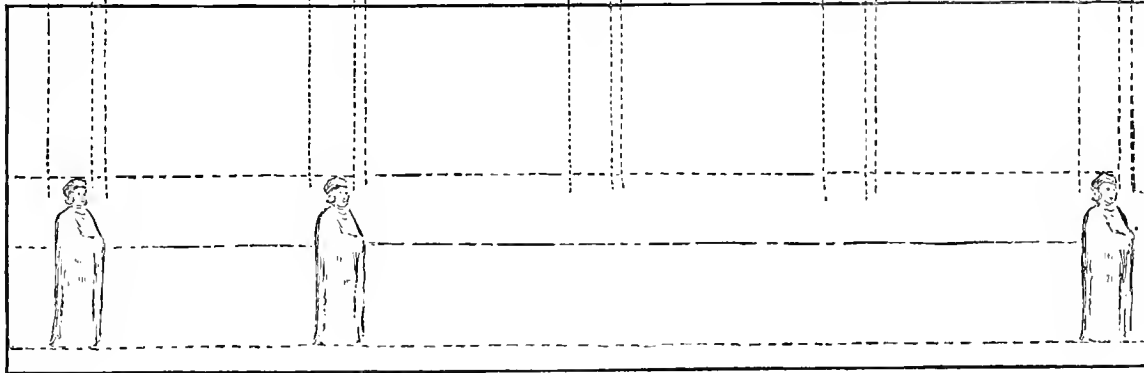

Fig. 135.

125 ; but this is by no means usual, and in Allston's case, at least, it is hardly to be regarded in any other light than that of an experiment.

What artists usually do is what Titian has done in the case we have just been regarding, viz. : To draw the architectural part of their subjects in true perspective as applied to a plane like our window-screen, and then to add the detached objects, such as figures, as if the observer were standing in front of each in his turn.

All columns and capitals, and a good many other details of buildings, are sufficiently detachable and have enough interest as separate objects to be treated in this way too, and it is customary so to treat them.

Straight lines, like those in pavements, walls, lintels, and roofs, have to be left as originally drawn in plane perspective, as they could not otherwise be made to agree with the spectator's idea of what level things ought to be, as derived from the lines of the room in which the picture was hung, and even from its own frame.

And, generally speaking, the connection of all square-cornered members with the long lines of the picture is so close that the rule given above has to be observed ; thus, a square post will usually be drawn as at A, Fig. 136, no matter how awkward the effect may be to an observer who does not occupy the station-point. But the circular one which might be made out of it would not, in the same position, be drawn as at B, which a strict regard for perspective would demand, but as at D instead, just as if the square stick from which it might have been made had been drawn as it is either at C or at E. As its lines are curves, there is no difficulty in reconciling them with the straight lines around them. Even the observer at the station-point does not notice that the posts are too small, and to everybody else they look a great deal better than they would have done if they had been drawn in true perspective.

As has just been said, this treatment has sometimes been extended to the long straight lines of the picture too, very notably by Turner ; and the result, where the architectural lines do not come too near the foreground, is certainly very delightful. The charm of it is to be ascribed partly to the picturesqueness of arrangement into which every detail of the picture necessarily falls when treated in this way, but partly,

also, to the association which a reflective observer discovers between the impression which the picture makes and that which he derives from nature.

Fig. 137, Turner's picture of the "Bridge at Coblenz," which is taken from Ruskin's "Elements of Drawing," is a first-rate example of this painter's application of the principles under discussion.

The eye wanders over such a picture as it does over nature, and finds everywhere the same retreating and converging lines, giving an idea of vastness which is not to be obtained in any other way.

Mr. Ruskin has felt the charm of the picture, and has written very beautifully about it, but, curiously enough, he has entirely failed to discover the real motive for the peculiarity of treatment which renders it interesting. He has a great deal to say about the currents of rivers and the desirableness of not building bridges level, but the fact that the whole matter is purely one of perspective effect has somehow eluded him.

A glance at the drawing, however, and a comparison of it with Fig. 125, will convince anybody that the curvature of the bridge is to be accounted for on this ground, and on no other.

Mr. Ruskin's theory, that bridges ought to have the highest arches where the water is deepest, may be a very good one, and Turner may have felt the same way about them, for aught we know. But there is nothing in the drawing before us to show that he had any opinion about it one way or the other. At any rate, the drawing of this bridge is not to be accounted for on any such grounds.

The curvature is exaggerated, it is true, for an observer would have to stand nearer to the bridge than the rest of the picture indicates, to obtain as much of a curve as this in running his eye along it; but the

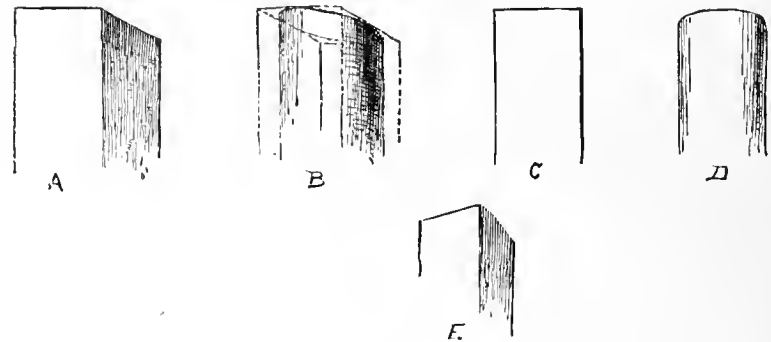

Fig. 136.

exaggeration is not a very great matter, after all, and the facts of nature have probably suffered quite as serious misrepresentation in the same picture in many things for which no good Turnerian would ever think of requiring an explanation.

And the fact is not to be denied, that in nature *the curve is there*. You can see it every time you run your eye along the roofs across the street, if you can only disabuse your mind of its preconceived notion that

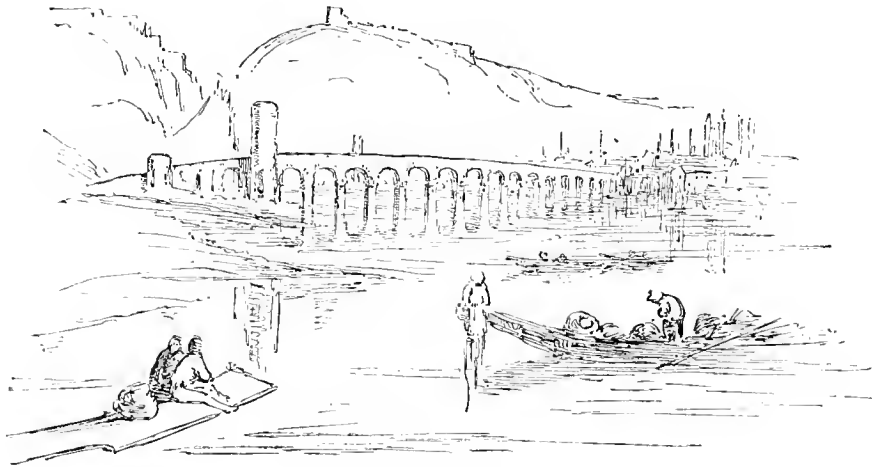

Fig. 137.

the roofs are level. Indeed, you can hardly see anything else in the lines of the sky, whose dome-like character is purely a matter of perspective effect, the actual curvature that exists in the stratification of all the clouds to be seen from any point on the surface of the earth being perfectly insignificant; and we perceive it, partly because the lines are so very long, but partly, also, because we do not have the flatness of the cloud-beds impressed upon us every moment of our lives, as we do the straightness of the edges of the buildings.

As a means of assisting the artist to reproduce the impressions which are made by nature, this modifica-

tion of details in accordance with the principles of cylindrical perspective is constantly resorted to, unconsciously, it may be, but none the less certainly:

Anyone painting an extended view out of doors represents distant objects, not as they would appear if projected upon a flat screen, but as if they were drawn on the inside of a cylinder, as Turner drew this bridge.

Whether it is, in general, desirable to carry the modification as far as Turner has done, in this and many other cases, it is not the purpose of this little book to discuss.

It is a poetic license, no doubt, but what would poetry be without its licenses? And what sacrilege it is to attempt to try such delightful productions as this by the standards of our dull prose!

It is to be distinctly understood, however, that the prose consists in limiting the painter who works on flat surfaces to the principles of plane perspective, not to the application of science, in its larger aspects, to his work. Turner's work is just as scientific as it is poetic, and furnishes as good an illustration as anyone could want of the truth on which teachers like to dwell—that scientific habits of thinking, and the power that comes with them, have no quarrel with the imagination, and offer no obstacle, but only helps, to its boldest flights.

THE END.



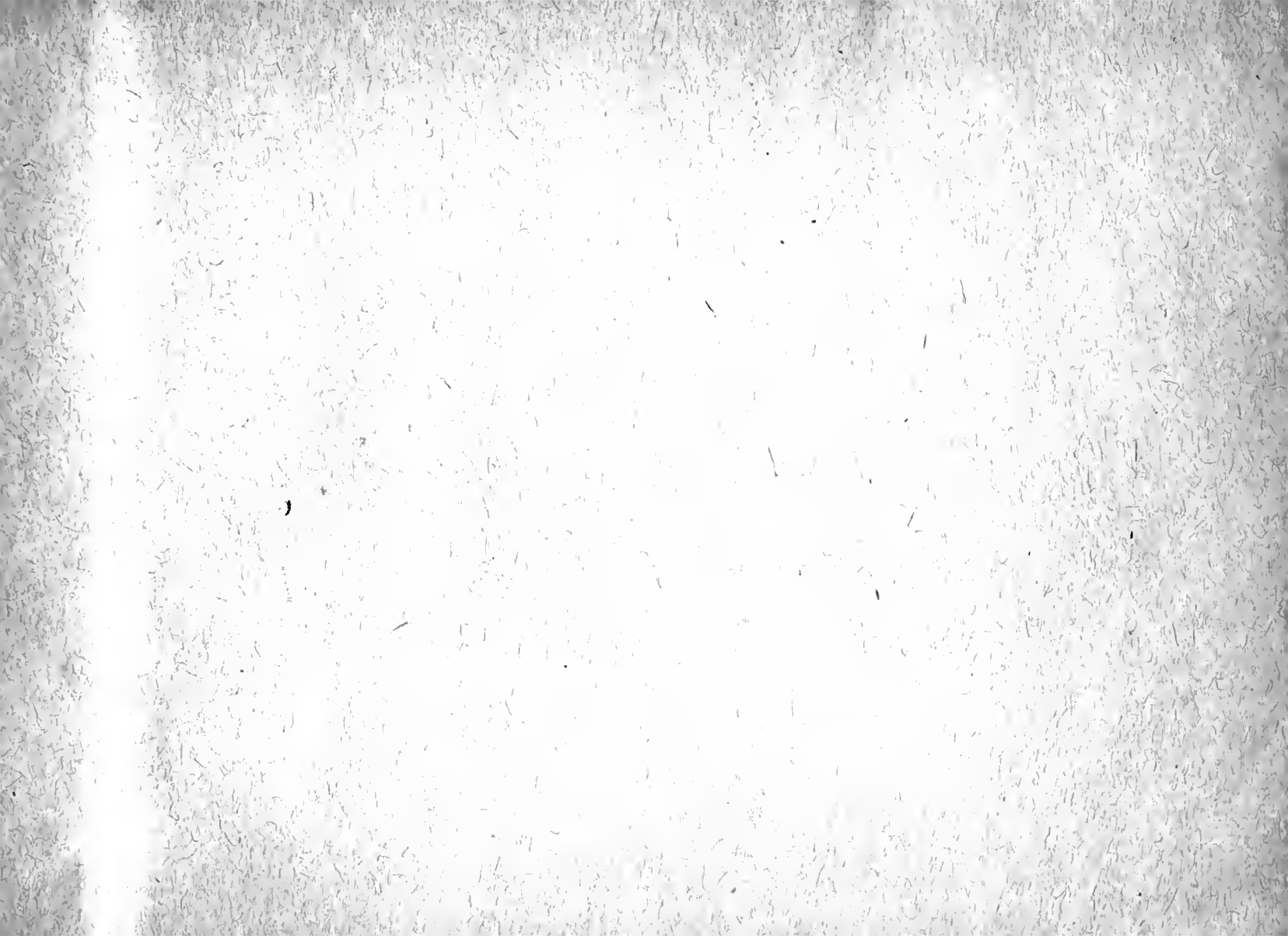

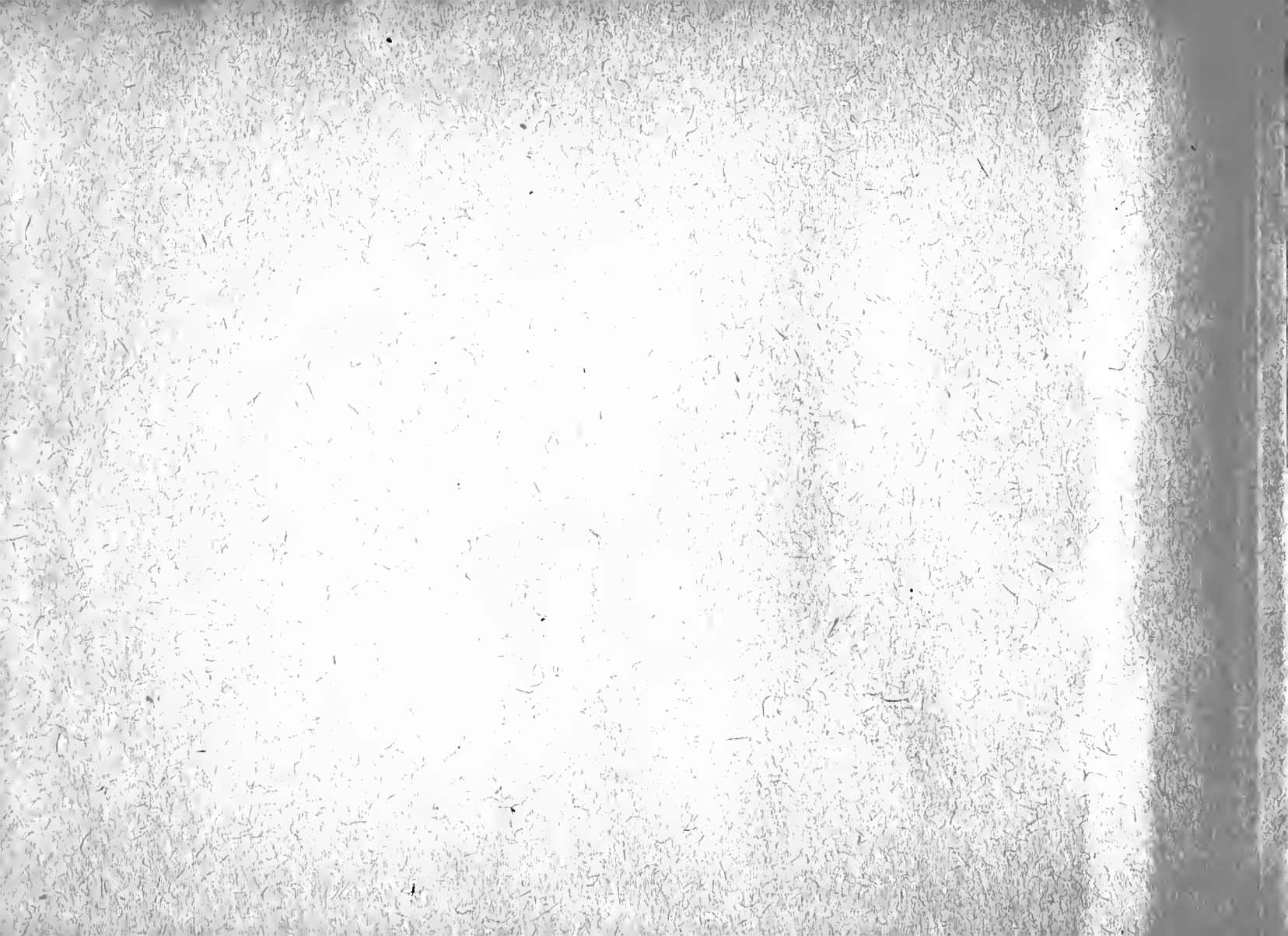

OCT 13 1928

